

# Science

Class Eight

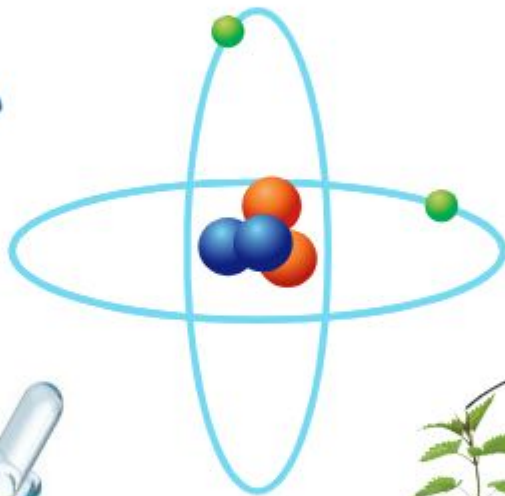

National Curriculum and Textbook Board, Bangladesh

Prescribed by the National Curriculum and Textbook Board  
as a textbook for class eight from the academic year 2013

---

# Science

## Class Eight

Revised for the year 2025

---

National Curriculum and Textbook Board, Bangladesh

**Published by**  
**National Curriculum and Textbook Board**

69-70 Motijheel Commercial Area, Dhaka.

---

**[All rights reserved by the Publisher]**

**First edition written, edited and translated by**

Prof Dr. Azizur Rahman  
Prof Dr. Shahjahan Tapan  
Prof Dr. Shafiur Rahman  
Prof S M Haider  
Prof Quazi Afroz Jahanara  
Prof Dr. S M Hafizur Rahman  
Mohammad Nure Alam Siddique  
Dr. Md. Abdul Khaleque  
Gul Anar Ahmed  
Prof Dr. Ali Asgar  
Dr. Md. Abu Masud  
Md. Abdur Razzaque Mian

First Publication : December, 2012  
Revised Edition : November, 2016  
Revised Edition : October, 2024

## Preface

---

The importance of formal education is diversified. The prime goal of modern education is not to impart knowledge only but to build a prosperous nation by developing skilled human resources. At the same time, education is the best means of developing a society free from superstitions and adheres to science and facts. To stand as a developed nation in the science and technology-driven world of the 21st century, we need to ensure quality education. A well-planned education is essential for enabling our new generation to face the challenges of the age and to motivate them with the strength of patriotism, values, and ethics. In this context, the government is determined to ensure education as per the demand of the age.

Education is the backbone of a nation and a curriculum provides the essence of formal education. Again, the most important tool for implementing a curriculum is the textbook. The National Curriculum 2012 has been adopted to achieve the goals of the National Education Policy 2010. In light of this, the National Curriculum and Textbook Board (NCTB) has been persistently working on developing, printing, and distributing quality textbooks. This organization also reviews and revises the curriculum, textbook, and assessment methods according to needs and realities.

Secondary education is a vital stage in our education system. This textbook is catered to the age, aptitude, and endless inquisitiveness of the students at this level, as well as to achieve the aims and objectives of the curriculum. It is believed that the book written and meticulously edited by experienced and skilled teachers and experts will be conducive to a joyful experience for the students. It is hoped that the book will play a significant role in promoting creative and aesthetic spirits among students along with subject knowledge and skills.

The purpose of science education is to develop observational skills, problem-solving skills, and interest of the students about natural phenomena and various elements of the environment through creating curiosity. In addition to the theoretical aspects of **Science**, this textbook for class VIII also provides different hands-on activities to increase their creativity and imagination, as well as investigative work to develop the student's curiosity and adherence to science. Students will be able to acquire the necessary skills and positive attitudes to secure personal and social safety and overcome various adverse situations through science practice.

It may be mentioned here that due to the changing situation in 2024 and as per the needs the textbook has been reviewed and revised for the academic year 2025. It is mentionable here that the last version of the textbook developed according to the curriculum 2012 has been taken as the basis. Meticulous attention has been paid to the textbook to make it more learner-friendly and error-free. However, any suggestions for further improvement of this book will be appreciated.

Finally, I would like to thank all of those who have contributed to the book as writers, editors, reviewers, illustrators and graphic designers.

October, 2024

**Prof. Dr. A K M Reazul Hassan**

Chairman

National Curriculum and Textbook Board, Bangladesh



# Contents

<b>Chapter</b>	<b>Title</b>	<b>Pages</b>
<b>One</b>	Classification of Animal World	1 – 13
<b>Two</b>	Growth and Heredity of Living Organism	14 – 24
<b>Three</b>	Diffusion, Osmosis and Transpiration	25 – 34
<b>Four</b>	Reproduction in Plants	35 – 46
<b>Five</b>	Co-ordination and Secretion	47 – 57
<b>Six</b>	The Structure of Atoms	58 – 68
<b>Seven</b>	The Earth and Gravitation	69 – 78
<b>Eight</b>	Chemical Reaction	79 – 92
<b>Nine</b>	Electric Circuits and Current Electricity	93 – 102
<b>Ten</b>	Acid, Base and Salt	103 – 113
<b>Eleven</b>	Light	114 – 123
<b>Twelve</b>	The Outer Space and Satellites	124 – 133
<b>Thirteen</b>	Food and Nutrition	134 – 152
<b>Fourteen</b>	Environment and Ecosystem	153 – 160

## Chapter One

# Classification of Animal World

The world is inhabited by numerous diverse small and large animals. There are various similarities and dissimilarities among them. From microscopic Amoeba to the gigantic whale, all are included in this diverse world of animals. The variety of animal depends on the diversity of environment. The variety of animals takes place due to variety of environment and habitat. It is a difficult task to understand the vast animal kingdom. To understand the animal world easily a systematic arrangement and grouping is necessary. The method of this systematic grouping/arrangement is called classification. Classification makes the way easy to understand animal kingdom



**At the end of this chapter we will be able to-**

- classify invertebrate animals;
- classify vertebrate animals;
- explain the necessity of classification of the living world.

### **Lesson 1 : Classification of animal world**

You can see various types of animals – small and large around you. Try yourself to answer the questions below, from the knowledge you have acquired in class six.

Questions:

1. Do all the animals you see look alike?
2. Do all of them have vertebral column?
3. Do they live in same habitat?
4. Do all of them take same food?
5. Do all of them have similar types of locomotion?

Now match your thoughts to the answers below. The animals which we see around us are not all alike. Their shape, structure as well as other physiological activities are also different. Some have vertebral column and some do not have.

Some of them live on land, some in water and some on trees. Their food is also of different kinds. These animals use different organs like fins, legs, wings, cilia and appendages for their movements. There are some animals who are sessile in form.

We do not have sufficient knowledge about the exact number of such diverse animals in the world. So far about 1.5 million species of animals have been discovered and the number is increasing day by day. Classification is an easy way to know the structure and nature of such huge number of animals. Morphological characteristics of the animal, similarity and dissimilarity among them and their interrelationship are the basis of classification. Depending on their characteristics they are grouped into different taxon serially. This step-wise grouping of the living world is known as classification. With the growing need of time, taxonomy has become a separate branch of Biology.

Species is the lowest rank of the taxonomic unit. For example; man, pigeon, toad etc. are separate species. To classify an animal, it is arranged step by step by considering its indigenous characteristics.

Aristotle, John Ray and Carolus Linnaeus are the notable names in the history of classification. Naturalist Carolus Linnaeus is called the father of taxonomy. In the naming of animals, he introduced binomial nomenclature and defined genus and species. Scientific name of an animal, contains two parts. The process of such naming is called binomial or scientific name. For example, *Homo sapiens* is the scientific name of human. Scientific name must be in Latin or Latinized language or in English.

Draw the following chart in your notebook and now fill in the gaps.

Name of Animal	Habitat	Structure	Usefulness	Harmfulness
Monkey				
Earthworm				
Mussel				
Bird				
Fish				

### Lesson 2-5 : Classification of invertebrate animals

In the modern classification, all animals belong to the Kingdom Animalia. In this classification, previously known phylum Protozoa is considered as a sub kingdom.

There are total 33 phyla of animals in Animalia world. Among these, nine phyla are called major phyla based on the number of species. The rest are non-major phyla. Animals in the first eight of these nine phyla are invertebrates and animals in the last phylum are vertebrates.



At a glance the classification of the major phyla of Animalia world.

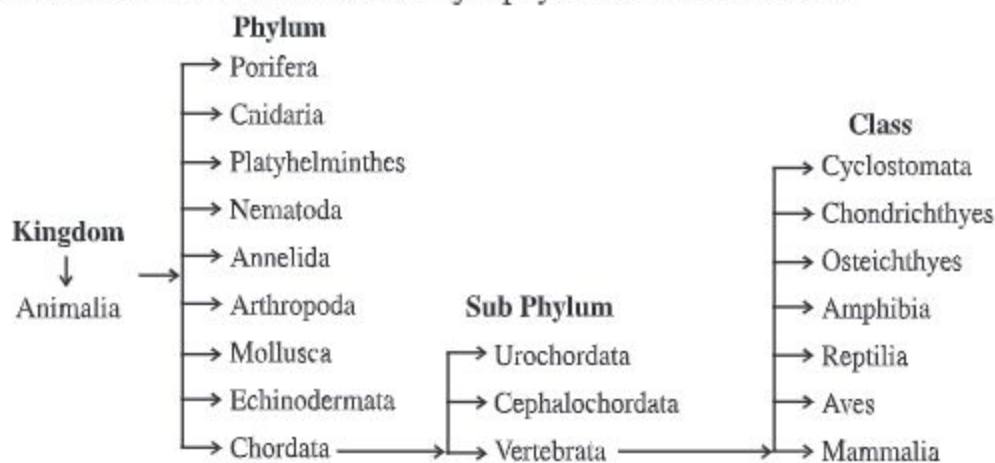

## 1. Phylum-Porifera

**Habit and habitat:** The word porus means hole and the word Ferre means to bear. The word porifera is derived from these two words. The member of the phylum porifera is commonly known as 'Sponge'. Their distribution is worldwide i.e. they are found all over the world. Most of the species are marine. But some live in fresh water. Usually they live in colonies.

### General characteristics

- Simplest multicellular animal. Though they are multicellular, they do not form tissue.
- Body wall with numerous pores. Through these pores food and oxygen enter into the body.
- No compact tissue, organ and organ system.



Fig. 1.1: Spongilla

Example : Spongilla, Scypha.

**2. Phylum-Cnidaria** This phylum is named from Cnidocyte, a cell of special characteristics. Phylum previously known as Coelenterata.

**Habit and habitat:** Members of this phylum are present in almost all the regions of the world. They are mostly marine. Many species found in canals, beels, rivers, lakes, fountains, etc. They are diverse in shape, size and colour. Some species live alone (solitary) and some live in groups forming colonies. They attach themselves to floating logs, leaves or other substance or move freely i.e. can swim freely.



### General characteristics

- Body consists of two embryonic layers. The outer one is ectoderm and the inner one is endoderm.
- Body cavity is known as coelenteron. It helps in digestion and circulation.
- Ectoderm bears a special type of cells called cnidocyte. These cells help in locomotion, defense, capture of prey.

Example : Hydra, Obelia.



Fig. 1.2 : Hydra

### 3. Phylum-Platyhelminthes

**Habit and habitat:** The word Platy means flat and helminthes means worm. The word Platyhelminthes is derived these two words. The life style of the member of this phylum is very colourful. Many species live on other organism as ecto-parasite (outside the body) or endo-parasite (inside the body). Some free living species live in fresh or saline water. Some animals of this phylum live in wet and damp soil. Fasciola and Taenia are under this Phylum.

#### General characteristics

- Body flat, bisexual and mostly parasitic.
- Ecto-parasite or endo-parasite.
- Body covered with thick cuticle.
- Body bears sucker and hooks.
- Flame cell present and acting as excretory organ.
- Digestive system is incomplete or absent.



a



b

Fig. 1.3 : a) Fasciola b) Taenia

Example : Fasciola, Taenia

### 4. Phylum - Nematoda (Also called Nematelminthes)

**Habit and habitat:** The word Nema means thread. This Phylum is named after this word. Many animals of this phylum are endo-parasite and live in the intestine and blood. These parasitic animals living in human body and animals cause harm to them. On the other hand, many are free living animals they live in water and soil. Ascaris, Wuchereria and Loa loa are under this phylum.

**General characteristics**

- Body tubular (cylindrical) and covered with thick skin.
- Digestive system complete. Mouth and anus present.
- Respiratory and circulatory system absent.
- Generally unisexual.
- Body cavity without lining and true coelom absent.

Example: Ascaris, Loa loa.



Fig. 1.4 : Ascaris

**5. Phylum - Annelida**

**Habit and habitat:** The word Annulus means ring. This phylum is named after this word. Annelids are found in almost all temperate and tropical regions of the world. Many species live in damp soil, fresh water and some live in deep sea water. A few species drag their burrows in stone and soil to live there.

**General characteristics**

- Body tubular and segmented.
- Each segment contains setae that helps in locomotion (exception -no setae in leeches).
- Nephridia present as excretory system.

Example : Earthworm, Leech.

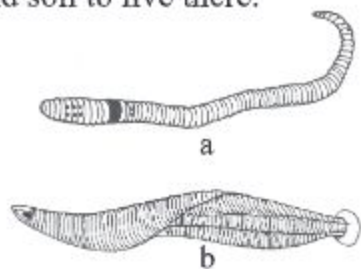

Fig. 1.5 : a) Earthworm, b) Leech

**6. Phylum - Arthropoda**

**Habit and habitat:** The word Arthro means joint and Podos means leg. This phylum is named after these two words. Arthropoda is the largest phylum of the animal kingdom. They can live everywhere and in every environment around the globe. Many species of them live as endo-parasite and ecto-parasite. Many of them can survive on land, in fresh water and in brackish (salty) sea water. Many species of this phylum can fly with the help of wings.

**General characteristics**

- In the body there are sub organs divided and jointed into three regions- head, thorax and abdomen.
- Head bears a pair of compound eyes and antenna.
- Soft body is covered with hard chitinous exoskeleton.
- There is an excretory organ called Malpighian ducts.
- Body cavity filled with blood and is known as haemocoel.

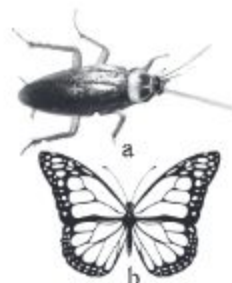

Fig. 1.6 : a) Cockroach b) Butterfly

Example: Butterfly, prawn, cockroach, crab.



## 7. Phylum- Mollusca

**Habit and habitat:** This phylum is named after the word Molluscus which means soft. This is the second largest phylum of animal world. The members of this phylum show diversity in their body form, habit and habitat. They live in almost all environment of the world. They are mostly marine and live in different zones of the sea. Some species live in hills and forest, while some live in fresh water

### General characteristics

- Soft body, usually covered with hard shell.
- Muscular foot used for locomotion.
- Gaseous exchange (Respiration) takes place by lungs or gills.

Example : Snail, Mussel.



Fig. 1.7 : Snail

## 8. Phylum: Echinodermata

**Habit and habitat:** The word Echinus means thorn and derma means skin. This phylum is named after these words. Echinoderms are all marine. They occur in all oceans of the world and at all depths. None of the members is found on land and in fresh water. Most of them live independently.

### General characteristics

- Dermal skin bears spine.
- Body is divided into five equal parts (i.e. pentamerous).
- A unique water-vascular system is present and locomotion is done by tube feet.
- No distinct head, dorsal and ventral surface in adults.

Example : Starfish, Sea cucumber.



Fig. 1.8 : Starfish

## Lesson 6-8 : Classification of vertebrate animals

### 9. Phylum - Chordata

**Habit and habitat:** The word Chordata originates from chorda which means cord or duct. Chordate lives in all sorts of environment of the world. Many species are terrestrial in habit. Among aquatic chordates, many species live in fresh water or in ocean. Many species are arboreal, desert dweller, polar, cave-dwelling and flying in nature. There are many ectoparasitic chordate species which live on the bodies of other animals.

### General characteristics

- The notochord is a rod-like unsegmented, semirigid structure. It forms a stiffening body axis throughout life or at some stage in the life cycle of each chordate.
- Single, dorsal, tubular nerve cord remain present in surface.
- Pharyngeal pouches (gill slits) present throughout life or at some stages in the life cycle.

Example : Man, Toad, Carp (Rui) fish.

Phylum chordata is divided into three sub-phylum. Such as-

#### (a) Urochordata

##### General characteristics

- Notochord present only in larval stage and restricted to the tail.
- Gill slits and dorsal tubular nerve cord present only in the early stage of the life cycle.

Example : Ascidia, Salpa.



Fig. 1.9 : Ascidia

#### (b) Cephalochordata

- Notochord and nerve cord found along the entire length of body and persist throughout life.
- Looking like fish.



Fig. 1.10 : Branchiostoma

Example: Branchiostoma

#### (c) Vertebrata

The member of this sub-phylum is known as vertebrate. Notochord is present only in embryonic stage and replaced by vertebral column in adults. Depending on structure and other characteristics, this sub-phylum is divided into seven classes.

#### (I) Class-Cyclostomata

- Body Slender, eel-like, rounded with naked skin.
- Fish like in form.
- True jaws and paired appendages absent.



Fig. 1.11 : Petromyzon



- Respiration by gills.

Example : Petromyzon.

## (II) Class-Chondrichthyes

### General characteristics

- All marine.
- Cartilaginous skeleton. The orifice is situated in the digitate portion of the body.
- Skin with placoid scales; 5-7 pairs of gills are present on both side of the head.
- Streamlined body with heterocercal tail but no operculum. The two parts of tail are of different shape that means heterocircle.



Fig. 1.12 : Hammer fish

Example: Shark, Sword fish.

## (III) Class-Osteichthyes

### General characteristics

- Mostly fresh water fish.
- The orifice is at the front side of the body.
- Skin with cycloid, ctenoid or ganoid scales; some without scale.
- Respiration primarily by gills. Four pair of gills are present on both side of the head. Gills are covered by operculum.
- Both parts of the tail are similar. That is homocircle.



Fig. 1.13 : Hilsa fish

**Task:** Collect Loitta, Rupchanda, Poa, Coral, Pabda, Shing (cat fish) and Magur (Cat fish). In which class do they belong? Identify their characteristics.

Example : Hilsa fish, Sea horse.

## (IV) Class-Amphibia

These animals can live under water breathing through their skin, but when on land they breathe by lungs. They lay their eggs in water and these hatch into larvae which breathe by gills.

### General characteristics

- Skin without scales.
- Skin thin, soft, moist and with many glands.
- Amphibians are cold-blooded animals.
- Lay eggs in water. A tadpole hatches from the fertilized egg.

Example : Frog, Toad.



Fig. 1.14 : Toad

**(V) Class-Reptilia****General characteristics**

- Skin dry and with scales.
- They move by crawling.
- Each of the four legs contains five toes (claws); absent in snakes and some lizards.

Example: Wall lizard, Crocodile, Snake.

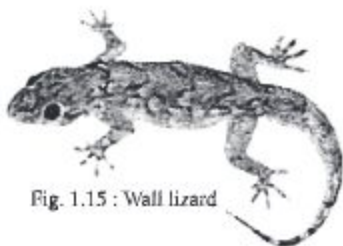

Fig. 1.15 : Wall lizard

**(VI) Class-Aves****General characteristics**

- Body is covered with feather.
- Two wings, two legs and one beak.
- The presence of air sacs with lung helps in flight.
- All birds are warm blooded.
- Bones are light, strong, delicate and laced with air cavities.

Example : Crow, Duck, Magpie.



Fig. 1.16 : Magpie ( Doel)

**(VII) Class-Mammalia****General characteristics**

- Body covered with hair.
- Female mammal suckle their young on milk from mammary glands.
- Warm blooded animal
- Four-chambered heart.
- Teeth heterodont (Varying in structure and function).
- All the mammal give birth to child. Example : Man, Camel, Royal Bengal Tiger. But their are some exception like Platypus.
- There are different types of gland in the skin.



Fig. 1.17 : Royal Bengal Tiger

**Task:** Make a group of five. Now, observe the chart of vertebrate and invertebrate animals; identify and note down their characteristics. Now present it to your class. Match the similarity of your findings with those of the other groups.

## Lesson 9 : Necessity of classification

The unit of classification is called taxon. Taxon helps to classify the vast animal world. The seven major taxa are as follows: Kingdom, Phylum, Class, Order, Family, Genus and Species. To identify an animal, taxonomists should match the characteristics of the animals with the above mentioned seven taxa. Sub-phylum is usually added under phylum.

Classification is a scientific approach by which we can gather knowledge about different plants and animals easily. It saves labour, money and time. Classification is essential to identify any animal including the newly discovered one. Interrelationship between different animals can be determined with the help of classification. We can determine the systematic position of the organisms according to the evolutionary trend. Organisms can be arranged into different taxa by following definite rule. This also allows us to trace the affinity of one group of organism to other. It is useful to determine the collective and systematic knowledge about organisms. For example, all acellular (Unicellular) animals are grouped under one phylum and all multicellular animals under nine phylum.

**New words:** Taxonomy, binomial nomenclature, species, animalia, coelom, coelenteron, setae, notochord, larva, cycloid, ganoid.

### What we have learned at the end of this chapter

- Vertebrata are advanced Animals. Their notochord is replaced by vertebral column consisting of hard vertebrae.
- Respiration by gills in aquatic vertebrate and by lungs in land vertebrate.
- Chordata is a phylum under the kingdom Animalia. Animals having notochord, nerve cord and pharyngeal gill slits are known as chordates.
- Anterior part of the nerve cord is swollen and transformed into brain. The skull houses the brain and protect it.
- Cellular layers of embryo that give rise to different organs are known as germ layer.
- Mantle covers the soft body of molluscs. They use their muscular foot for locomotion.



- Radial symmetry applies to those forms that can be divided into similar halves by more than two planes passing through one main axis. Example-Starfish.
- Cavity surrounded by body wall is known as coelenteron. It acts as digestive as well as circulatory system.
- The space filled with fluid between body wall and the alimentary canal of multicellular animal is known as coelom.
- Haemocoel is filled with blood and acts as a part of circulatory system.
- Arthropoda is the largest phylum of the animal kingdom. Harmful insects are known as pest.

## Exercise

### Fill in the blanks

1. Excretory system of liver fluke is \_\_\_\_\_.
2. Blood filled body cavity of prawn is known as \_\_\_\_\_.
3. \_\_\_\_\_ use muscular foot for locomotion.
4. Members of the sub-phylum \_\_\_\_\_ are known as vertebrate.
5. Members of the sub-phylum Urochordata have \_\_\_\_\_ in their tail.

### Short Answer Questions

1. How many parts are there in binomial nomenclature of an animal ?  
Mention the name of these parts. What is the scientific name of human?
2. Write the names of five known arthropods.
3. Which phylum does prawn belong to ? What are the characteristics of this phylum.
4. Mention the characteristics of mammals.
5. What are the characteristics of Urochordata ?

### Multiple Choice Questions

#### 1. Which animal belongs to the phylum Mollusca?

- |             |           |
|-------------|-----------|
| a. Crab     | b. Leech  |
| c. Starfish | d. Mussel |



**2. Both Scypha and Hydra are-**

- i. Diploblastic
- ii. Multicellular
- iii. Devoid of well developed organ system.

**Which one of the following is correct?**

- |             |                |
|-------------|----------------|
| a. i & ii   | b. i & iii     |
| c. ii & iii | d. i, ii & iii |

**Based on the chart below, answer questions no. 3 & 4**

m	Animal having wing and haemocoel.
n	Animal having feather and air sacs with lung
o	Cold-blooded animal and lays eggs
p	Animals with scale and paired fins

**3. Which animal of the chart is invertebrate?**

- |      |      |
|------|------|
| a. m | b. n |
| c. o | d. p |

**4. Can fly-**

- i. m & n animal
- ii. n & o animal
- iii. m & p animal

**Which one of the following is correct?**

- |            |                |
|------------|----------------|
| a. i       | b. i & ii      |
| c. i & iii | d. i, ii & iii |

**Creative Questions**

1.

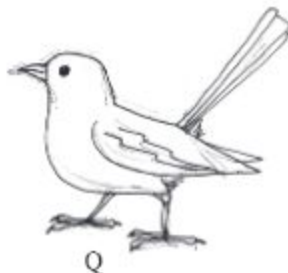
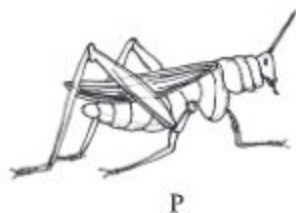

- What is classification?
  - What do you mean by scientific name?
  - In which class animal 'P' belongs to ? Explain.
  - Explain why these two animals belong to different classes.
2. Rahat caught a mosquito just after being bitten. He examined its appendages, eye and body covering with the help of a magnifying glass. Then he tried to understand its systematic position in light of his textbook knowledge.
- In which phylum tape worm belongs to?
  - Explain the position of notochord in human body.
  - Based on Rahat's observation, explain the systematic position of the animal.
  - Why it is important for Rahat to know the systematic position of the animal? Explain.

**Do it yourself**

- Collect some vertebrate animals from your environment/locality and write down their characteristics.
- Mention the phylum of the following animals – earthworm, prawn, grasshopper, snail, mussel, rui fish and magpie-robin (Doel). Make a list of their identifying characteristics.

# Chapter Two

## Growth and Heredity of Living Organism

Body of all organisms consists of cell and all cells arise from the division of existing cells. Unicellular organisms multiply by cell division. In this way one cell divides into two, and two transforms into four. They divide further in the same manner and this is how growth of living organism takes place.

The cells found in most multicellular organisms originate from the divisions of a single cell. The life of a multicellular organism originates from the zygote—the union or fertilization of an egg and a sperm. Cell division provides the basis for one form of growth, for both sexual and asexual reproduction.



**At the end of this chapter we will be able to —**

- explain the types of cell divisions;
- explain the growth and development of living organism through cell division;
- explain what role cell division plays to restore genetic trait.

### Lesson 1 : Types of cell division

In living organism three main types of cell divisions are found, such as, (1) Amitosis (2) Mitosis and (3) Meiosis.

**Amitosis:** Amitosis cell division occurs in Bacteria, yeast, fungi and in amoeba. Unicellular prokaryotes procreate through amitosis cell division. The nucleus elongates and becomes dumb bell shaped and becomes slender in the middle and gets separated from each other to form two nuclei. At the same time the cytoplasm also elongates in the middle to form two cells. In this kind of cell division, the nucleus of mother cell and cytoplasm get directly separated to form two cells. Hence it is called direct cell division.

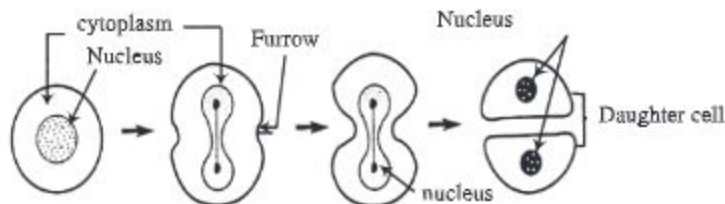

Fig. 2.1: Amitosis (direct cell division).



**Mitosis** : Somatic cells of higher plants and animals are divided in mitosis cell division. The process of cell division by which nucleus and chromosomes of a eukaryotic cell gets divided only once is known as mitosis. In this process the nucleus of the mother cell is divided only once and produces two daughter cells bearing similar characteristics and having same size, quality and number of chromosomes. Mitosis ensures increase of height and breadth of the body of animals and plants. The cells of the meristematic (apex of branch and roots) tissue of plant increase their number by mitotic division.

**Meiosis** : Meiotic cell division occurs during the formation of reproductive cell from the reproductive mother cells. The characteristics of meiotic cell division is that the nucleus is divided twice and chromosomes divide once. As a result of cell division by meiosis the number of chromosomes of the daughter cells becomes half of the number of chromosomes of mother reproductive cells. In this process four new cells are produced which contain half of the chromosomes of the mother cell, hence called reduction division. Generally meiosis occurs in the reproductive mother cell during the formation of gametes.

## Mitosis

### The features of mitosis

1. Mitotic cell division is the division of somatic cell.
2. In this process the nucleus of the mother cell is divided only once.
3. Mother cell is divided into two cells of same quality.
4. The number of chromosome of daughter nucleus and mother nucleus remain identical after mitotic cell division.
5. In mitosis division, each chromosomes equally divided lengthwise along the centromere. As a result the number of chromosomes of the two new cells remain same as the number of chromosomes of the mother cell. So, mitosis is also known as equational division.

### Where mitosis occurs ?

Mitosis takes place in the somatic cells of all eukaryotic organisms. The meristematic tissue of the growing part of the plant, viz, apex of stem and roots, growing leaves, buds etc. show this type of cell division. Mitosis occurs in somatic cells of the animal body, developing embryo and during asexual reproduction of lower animals and plants.



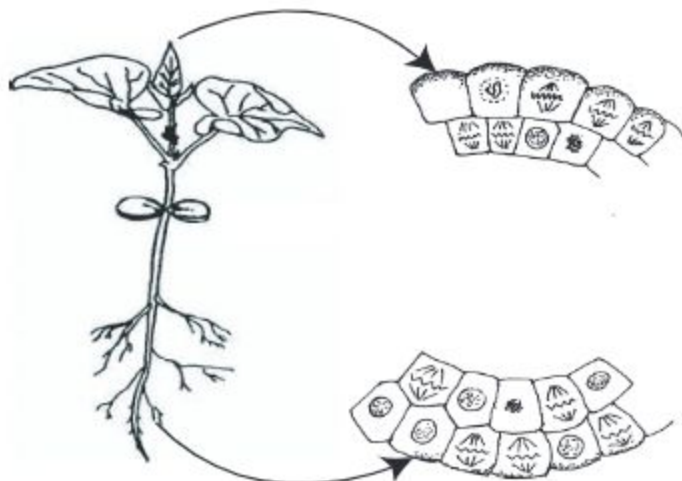

Fig. 2.2: Cell division in root tip and shoot tip.

### In which cells mitosis does not occur?

In case of animals the nerve cells (neuron) of the nervous tissue, matured red blood corpuscles (RBC) and platelets of mammals and the cells of permanent tissue of plants does not show mitosis cell division.

## Lesson 2 : The process of mitosis cell division

The process of mitosis takes place in two phases. The nucleus divides in first phase and cytoplasm in the second phase. The division of nucleus is known as caryokinesis and the division of cytoplasm is cytokinesis. Mitosis is a continuous process in which caryokinesis ( division of nucleus) occurs first and then cytokinesis (division of cytoplasm) takes place. Before starting caryokinesis and cytokinesis the nucleus of the dividing cell need to take some preparations. This intermediary stage between the two consecutive cell divisions is known as interphase or resting stage.

### Division of nucleus or caryokinesis

The nucleus of the dividing cell passes through a continuous complex process and completes caryokinesis. As cell division is a non-separable continuous process, it is not right to divide them into different stage. Still for the benefit of description, it is divided into five stages. These are (1) Prophase (2) Pro-metaphase (3) Metaphase (4) Anaphase and (5) Telophase.

**Prophase:** This is the longest stage of mitosis cell division. At this stage the following events occurs.

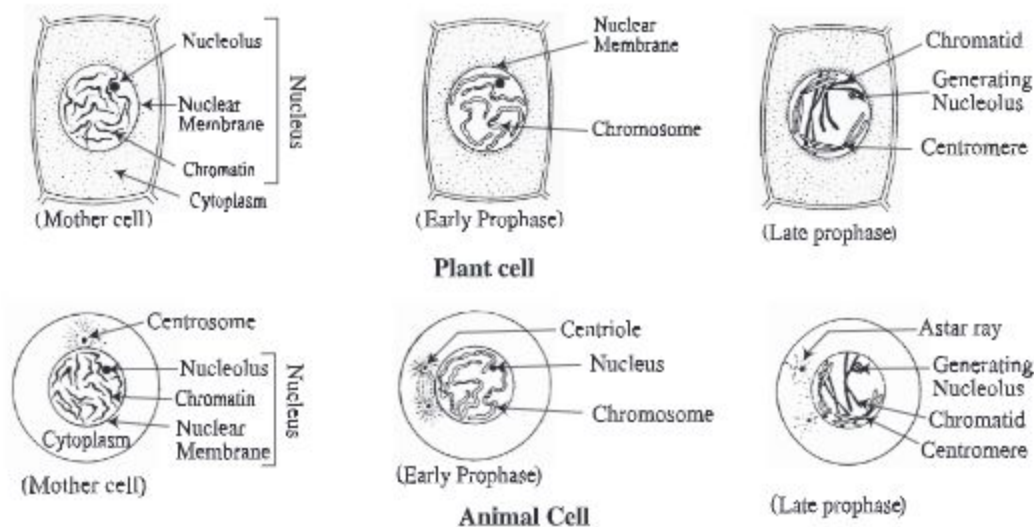

Fig. 2.3: Prophase

1. The nucleus becomes bigger in size.
2. Due to continuous dehydration nuclear chromatin condenses to form visible thread like structure, known as chromosome. Then each chromosome divides longitudinally into two chromatid. The sister chromatids are joined together at their centromere.

### Lesson 3 : Pro-metaphase, metaphase, anaphase and telophase

**Pro-metaphase:** This phase is very short. In this phase-

1. Nuclear membrane and nucleolus almost disappears.
2. At the end of prophase spindle apparatus is formed by the accumulation of some protein fibre in the cell. The middle area of two poles of the spindle apparatus is known as equator. The fibres of the spindle spread from one pole to another. These are known as spindle fibre. In animal cells, in addition to formation of spindle apparatus, centriole divides earlier and reaches the two poles from where aster fiber radiates. Each mechanism of a spindle machine is called spindle machine. The mechanisms which connect with the centromere of the chromosomes are called traction fibers or attraction fibers.

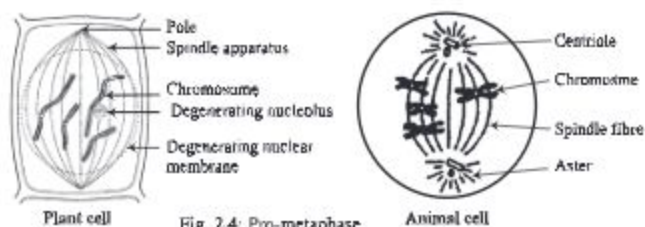

Fig. 2.4: Pro-metaphase

**Metaphase :** In this step-

1. All the chromosomes come and locate at the equator of spindle apparatus and get attached to the centromere by spindle fibre.
2. At this stage the chromosomes are found shortest, quite thick and clear.

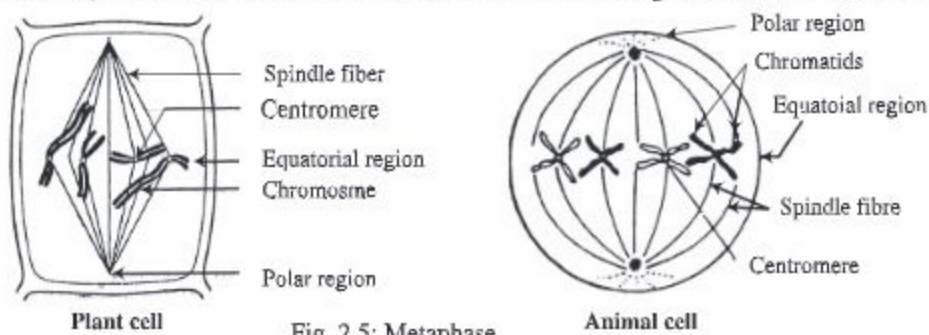

Fig. 2.5: Metaphase

**Anaphase :** In this stage-

1. The centromere of the chromosome now splits so that two independent daughter chromosome, each with its own centromere, are formed.
2. The chromatids get separated from each other. At this stage each chromatid is called daughter chromosome.
3. Then the contraction of the attraction fibers attached to the chromosomes causes half of the daughter chromosome to move towards the north pole and half towards the south pole. In this time, the chromosomes take the shape of English letter V, L, J or I according to the position of centromere.

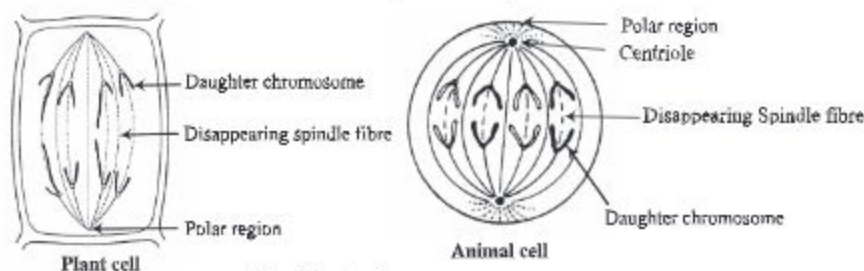

Fig. 2.6: Anaphase

**Lesson 4 : Telophase :** In this stage-

1. Daughter chromosomes reach their opposite poles.
2. Spindle fibre disappears and the chromosomes lose their identity, reverting to a diffuse chromatin network.
3. Finally, nuclear membrane reappears around the two daughter nuclei. Nucleolus also reappears. In this way, two daughter nuclei formed at two poles and signal the end of karyokinesis.



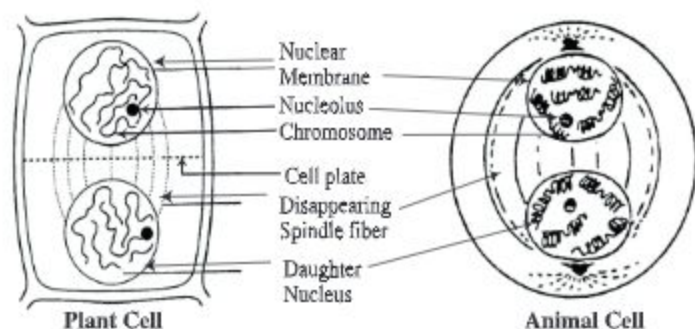

Fig. 2.7: Telophase

### Cytokinesis

At the end of telophase, cytokinesis starts. In plant cells the equatorial region of the spindle apparatus gradually becomes wide and touches the cell wall and the fibres disappear. At the equatorial region fragments of the endoplasmic reticulum are deposited and they combine together to form a membrane called plasmalema. By deposition of other components on the plasmalema, cell plate is formed. Cell wall is developed by the deposition of hemicellulose and other components on the cell plate. By the development of the cell wall the mother cell divides into two daughter cells.

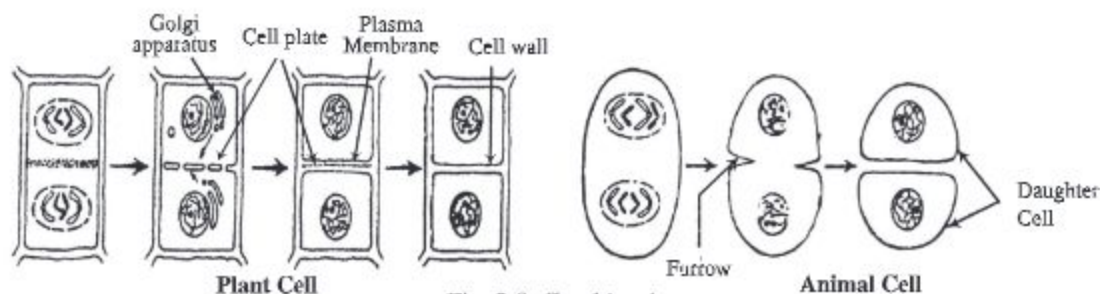

Fig. 2.8: Cytokinesis

In animal cell, a cleavage furrow appears on the surface of the dividing cell and encircles it at the midline of the spindle. The cleavage furrow deepens and pinches the plasma membrane as though it were being tightened by an invisible rubber band and gradually draws the furrow inward. Finally, the infolding edges of the plasma membrane meet and fuse, completing cell division.

### Lesson 5 & 6 : Meiosis

At the beginning of this chapter we have learnt what Meiosis is. The question is now, why meiosis occurs?

In mitosis, mother cell divides and produces two daughter cells bearing same number of chromosomes as in mother cell. Mitosis is essential for growth and asexual reproduction. In case of sexual reproduction two gamete (male & female) cells unite together to form a zygote. So, if the number of chromosome in gamete cells does not reduce to half of the mother cell, the number of chromosome becomes double as a result of the union of the two gametes. In case of meiosis mother cell divides and produces daughter cells bearing half the number of chromosomes of mother cell. The number of chromosome remain same, as the mother cell, in the newly formed zygote resulted from the union of such two gamete cells. As a result of cell division by meiosis the number of chromosomes of a species remains constant generation after generation. This happens during formation of gamete and in certain stage of life cycle of the lower plant. This stage of chromosome is called haploid ( $n$ ). When two haploid cell unite, the state of chromosomes is called diploid.

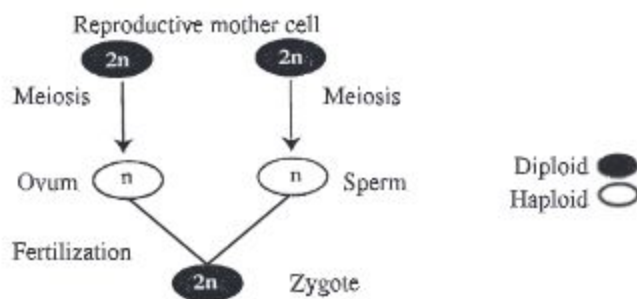

Fig. 2.9 : Formation of zygote due to meiosis cell division.

So, the features of the organism are retained in the successive generation by meiotic cell

### Features of Meiosis

1. Meiosis takes place in the reproductive mother cell of diploid organism and in the zygote of haploid organisms (lower plants).
2. Four haploid daughter cells are produced from a single cell.
3. In this process the nucleus divides twice and chromosomes divide once.
4. The four daughter cells thus formed contain half the number of chromosome of the mother cells.

### Where meiosis takes place?

Meiosis takes place in the diploid ( $2n$ ) reproductive mother cells during formation of gamete. Meiosis occurs inside the stamen and carpel of flowering plants and in the testes and ovary of higher animals. Meiosis occurs in the zygote of haploid ( $n$ ) organism.



### Meiosis cell division

During meiosis cell division, a primordial germ cell is divided in two successive phases. First phase is called meiosis-I and the second phase is known as meiosis-II. During the first division, chromosomes of the daughter cells become half of the mother cells. Second division is same as mitosis. It means that cells produced in the first division again divide into two daughter cells. As a result, four daughter cells ( $n$ ) are produced from each primordial germ cell ( $2n$ ).

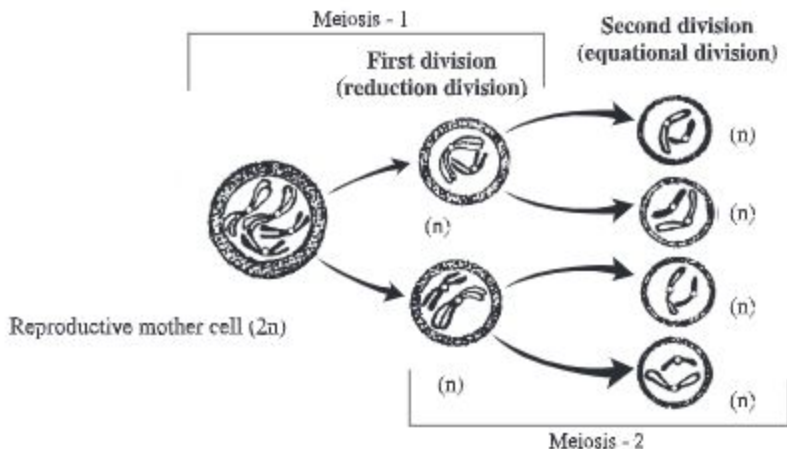

Fig. 2.10: Concept of meiosis cell division.

### Lesson 7-9 : The role of chromosome, DNA and RNA in determination of heredity

Children inherit some characteristics of their parents. The process by which characteristics from parent are inherited to the offsprings is called heredity. Characters inherited to children is known as hereditary characters. Once, the knowledge of heredity was imaginary. Later on, scientists explain how these characters inherit to offsprings from their parent.

During the second half of the nineteenth century Gregor Johann Mendel first postulated two laws about how the traits of the parents are transmitted to the offsprings. The research of Mendel and his laws of genetics are now well established as an important branch of life science. The modern theory of heredity that prevails today, is based on the theory discovered by Melend. This is why Johann Mendel is called the father of heredity.



Gregor Johann Mendel  
(1822-1884)



The nucleus of a cell contains a fixed number of thread-like objects that bear the hereditary characters of the organism are called chromosome. These are only visible when a cell is about to divide into two i.e. during prophase stage of meiosis cell division. Each chromosome consists of two parts-chromatid and centromere. At prophase stage of meiosis cell division, each chromosome divides longitudinally into two equal parts, known as chromatid. The point where sister chromatids are joined is called centromere. During cell division, the spindle fibres are attached to centromere.

### **Nucleic Acid**

Nucleic acids are of two types-namely DNA (deoxyribonucleic acid) and RNA (Ribonucleic acid). DNA is the main component of chromosome. DNA & RNA play vital role in transmission of hereditary traits.

It is accepted by all that the genes which are located in the chromosomes control the characteristics of organisms. It is proved from different experiments that, parts of DNA act as gene, i.e. DNA itself is gene. DNA is directly transmitted from the parents to the progeny.

In case of some virus, DNA is absent (eg. TMV). But in place of it, there is RNA. In these cases, RNA is the hereditary material. A character of an organism may be controlled by more than one gene, again a single gene may control several characters. The eye colour, hair pattern, skin colour etc. of man are controlled by gene. Like man, characters of other animals and plants are also controlled by gene. Chromosome acts as carrier and transmit gene from one generation to next generation, thus maintains the continuity of hereditary traits.

The continuity of such hereditary trait is maintained through meiosis cell division. To maintain hereditary trait, chromosome carries gene directly from parent to offsprings during cell division. For this reason, chromosome is known as the physical basis of heredity.

So, from the above discussion we understand that the hereditary trait is maintained by meiosis and through reduction of chromosome number, the individuality of every species is restored.

In human body, each somatic cell bears 46 chromosomes. How many chromosomes do germ cell and embryo (embryonic) cells contain?

**New words :** Amitosis, mitosis, meiosis, haploid, diploid, spindle fibre, cytokinesis, DNA, RNA, daughter cell, zygote

### **What we have learned at the end of this chapter**

- Growth of organism occurs by cell division.
- How many types of cell division and where these occur.
- How does the chromosome number in organism remain constant?
- What do we understand by haploid and diploid?
- Gene is the carrier of heredity and chromosome transmits them from generation to generation.
- Gregor Johann Mendel is the father of genetics.

## **Exercise**

### **Fill in the blanks**

1. In \_\_\_\_\_ stage the chromosomes with their chromatid take position at the equatorial region.
2. Reduction of chromosome occurs in \_\_\_\_\_ division.
3. In *Amoeba* \_\_\_\_\_ is found.
4. The nature of chromosome in somatic cells is \_\_\_\_\_.
5. The division of nucleus is called \_\_\_\_\_.

### **Multiple Choice Questions**

1. In which stage of mitosis chromosomes becomes shorter and thicker?
  - a. Prophase
  - b. Pro-metaphase
  - c. Metaphase
  - d. Anaphase
2. Which of the following controls eye colour?
  - a. DNA
  - b. RNA
  - c. Nucleolus
  - d. Centromere

**Read the following paragraph and answer questions no. 3 & 4**

Safwan was examining the root cell of onion under a microscope. In a cell division stage he found that there is no nuclear membrane and nucleolus, but chromosomes are located right in the middle.

3. Which stage of cell division Safwan observed?
- Prophase
  - Pro-metaphase
  - Metaphase
  - Anaphase
4. In the next phase of Safwan's observation-
- chromosomes get detached from centromere
  - chromatid segregates from each other
  - centromere divides into two sections

**Which one of the following is correct?**

- i & ii
- i & iii
- ii & iii
- i, ii & iii

**Creative Questions**

1. Mr. Farabi, the class teacher, was discussing cell division in the science class. He said, during a stage in cell division, thread like centromere in the nucleus divides into two parts. As a result the number of chromosomes remain unchanged in the divided cells
- Which type of cell division produces germ cells?
  - What do you mean by amitosis? Explain.
  - Describe with diagram the stage of cell division that Mr. Farabi describes.
  - Explain the role of thread like structure that Mr. Farabi describes.

2.

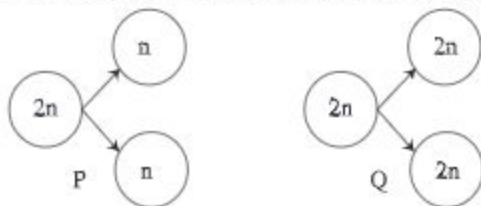

- How many chromosomes are there in a human somatic cells?
- What do you mean by gene?
- Explain cell division P?
- In case of higher animals compare the cell divisions P and Q.



## Chapter Three

# Diffusion, Osmosis and Transpiration

The roots of plants absorb water and minerals from the soil. These substances are transported up the stem to the leaves, where it evaporates from the surface. Intake of carbon dioxide, release ( expel) of oxygen gas, absorption of water and minerals and transport of these substances to the roots and leaves and evaporation of water occurs through diffusion, osmosis, absorption, transportation and transpiration processes.

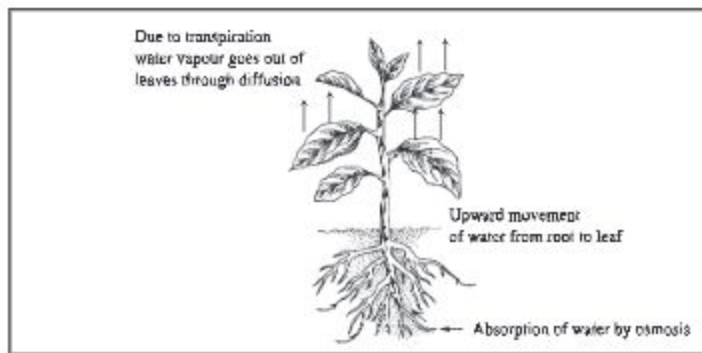

**At the end of this chapter, we will be able to—**

- explain diffusion process;
- explain process of osmosis;
- explain loss of water through transpiration;
- explain absorption of water by plants.

### Lesson 1-2 : Diffusion

We know, matters (substances) are made up of small molecules. These molecules are always in motion. In case of liquid and gas, the motion of these molecules are very fast and show tendency to diffuse towards the regions with lower concentration from higher ones. This movement of molecules continues as long as the concentration of the two regions becomes equal. Diffusion stops at once when the concentration of molecules becomes equal in two region. This type of movement of molecules is called diffusion.

Due to kinetic energy of the molecule, a potential pressure is exerted and consequently the movement of molecules of solutions or gases from one region of higher concentration to that of a lower one occurs. This type of pressure is called diffusion pressure.

We can understand the meaning of diffusion through some experiments. Depending on experimental knowledge and discussion, practical knowledge on diffusion can be gathered. A few experiments on diffusion are discussed below- We can see many examples of diffusion in our surroundings. For example, the smell of scent, ator or burning incense spread all around the room. It happens due to diffusion. High density of atoms from incense and scent spread in low density of atoms arounds the room. As a result, the whole room becomes scented.

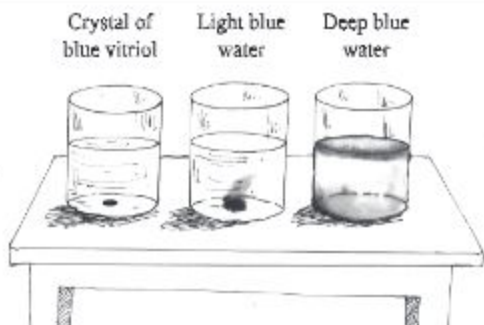

Fig. 3.1: Diffusion test of Scent

**Activity:** Observing diffusion of copper sulphate in water.

**Requirements:** Copper sulphate, beaker, water, etc

**Method:** Take some copper sulphate (blue vitriol) and pour them into the water of a beaker. Copper sulphate is soluble in water and water will take the colour of copper sulphate. Explain why it happens. Finally prepare a list of diffusion activities which occur around us.



**Importance of diffusion :** Diffusion takes place in every physiological process of the organism. During photosynthesis, plants absorb carbon dioxide and release oxygen as by products. Diffusion makes this essential task possible. Living cells use oxygen for the oxidation of glucose. Oxygen enters into the cells through diffusion and the release of carbon dioxide also occurs in the same way. The loss of water in the form of water vapours through transpiration is the result of diffusion. In case of animal respiration, exchange of oxygen and carbon dioxide, carrying of food, oxygen etc. from blood to lymph and from lymph to cells occur through diffusion.

### Lesson-3 : Osmosis

To understand the process of osmosis, we need to know the characteristics of the membrane separating two differently concentrated solutions. Membrane may be of three types. For example; impermeable membrane, permeable membrane and semi-permeable membrane



**Impermeable membrane:** The membrane through which molecule of both solute and solvent cannot pass. Example- polythene, cell wall made up of cutin.

**Permeable membrane:** The membrane through which molecule of both solute and solvent can pass easily. Example- cell wall.

**Semi-permeable membrane:** The membrane through which only the solvent molecule ( water in case of plants) can pass (but not the solute molecules) is called semi-permeable membrane. Example- cell membrane, membrane inside the egg shell, membrane of fish potka (swim bladder/air bladder), gallbladder membrane of animal etc.

We see that if a raisin or dried grape (kismis) is kept under water for sometime, it swells up. It happens because dry grape absorbs water and the absorption of water occurs through osmosis. Osmosis is one kind of diffusion. Osmosis occurs only in case of liquid and a semi-permeable membrane keeps the two liquid separate. For our understanding, the example of dry grape is cited here.

We know, when two differently concentrated solutions are kept together, diffusion occurs naturally. Look, the raisins or dry grapes have shrunk because the water inside them is dried up. Now, if dry grapes are kept in water, the water molecules diffuse into the dry grapes as the concentrated sucrose solution inside the dry grapes are separated from water by a membrane. Consequently, only the water molecules

enter into dry grape through the membrane whereas sucrose molecules don't enter. molecule does not. This type of membrane is known as semi-permeable membrane. So, the membrane through which only solvent molecule can pass, but not the solute molecule, is called semi-permeable membrane and the process is known as osmosis. If two differently concentrated solutions of same solvent is kept separated by a semi-permeable membrane, the solvent from dilute solution diffuse through the semi-permeable membrane into the high concentrated solution and this process is called the osmosis. In other words, solute flows from the region of higher concentration to the region of lower concentration through the semipermeable membrane.

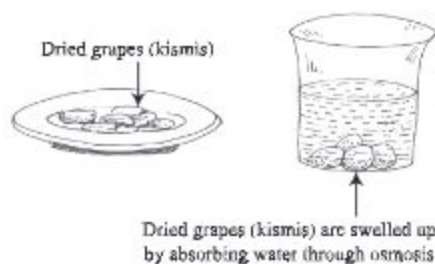

Fig. 3.2: Osmosis experiment with dried grapes (kismis)

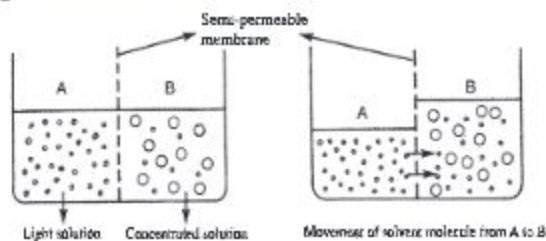

Fig. 3.3: Process of osmosis



## Lesson 4 : Importance of osmosis

Cell membrane or plasma membrane of the living organism acts as semi-permeable membrane. Mineral salts dissolved in water, enter into and pass out from the cell through plasma membrane. Intra cellular water and the mineral salt solution together is called cell sap or simply sap. So, osmosis plays a very important role in maintaining different physio-chemical process of the cell. By this process, plants absorb water and minerals dissolved in water from soil, through unicellular root hair.

Due to osmosis turgidity of the cell is increased that keeps stem and leaf fresh and straight. Also plants can open and close its petals. In the intestine of the animals digested food may be absorbed.

**Activity :** Experiment of osmosis.

**Requirements :** Thistle funnel, swim bladder (air bladder), beaker, concentrated sugar, stand, clamp

**Method:** After covering the wide mouth of the thistle funnel by fish potka, it should be tied tightly with the help of a thread. Beaker to be filled half with water. The funnel to be filled with sugar solution and placed in a water-filled beaker clamped with a stand. The height of sugar solution to be marked with the help of marker pen. Keep the experimental set in a place.

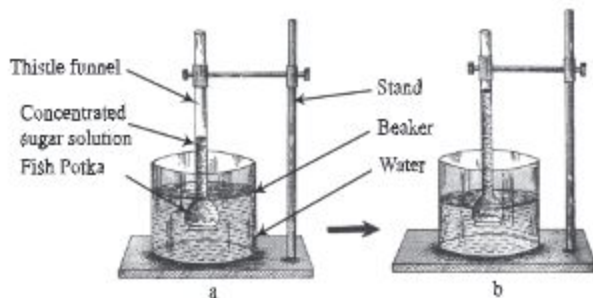

Fig. 3.4 : Experiment of osmosis  
(a) At the beginning of the experiment (b) After few hours of the experiment.

**Observation:** After sometime, we can see the height of the solution in the thistle funnel tube has gone up. Sometime later, we can see the level of the solution does not rise further.

Now answer the following questions in the light of what you have observed from the experiment.

1. What type of membrane does the fish potka have?
2. Why did sugar solution rise inside the funnel tube?
3. Why did the solution of the funnel become static without rising upwards?

## Lesson 5 : Absorption of water and mineral salts

**Mechanism of water absorption in plants:** The process by which living cells of the plant body intake water and mineral salt dissolved in water is generally known as absorption. Terrestrial (land) plants absorb water from soil through root hairs. Submerged plants absorb water through their whole body. The root hairs of the terrestrial plants intake capillary water of the soil particles through osmosis.

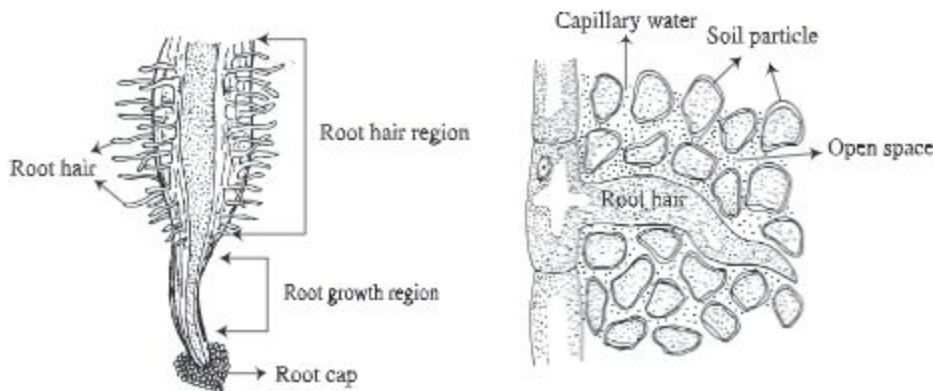

Fig. 3.5: Different regions of root

The wall of the root hair is permeable. So first it absorbs water through imbibitions and the absorbed water comes in contact with semi-permeable plasma membrane below the cell wall. The concentration of the central solution of the root hair is higher than that of its environment and thus water (solvent) enters into the cell through endosmosis. The concentration of the cell sap from the outer membrane to the centre of the root cells is not equal. Consequently due to inter cellular osmosis water flows from one cell to another and finally reaches the leaves through xylem vessels of the stem.

**Imbibition:** Most of the colloidal substances are hydrophilic. Plant body contains various colloidal substances, such as starch, cellulose, gelatine, etc. These substances can absorb water because of their colloidal nature. The process by which colloidal substances (cell wall in plants) absorb different liquid (water in case of plants) is called imbibition. And the absorbing substance is called hydrophilic substance.

### Absorption of mineral salt by plants

Plant absorbs a good deal of mineral salt from the soil for their development and physiological need. Mineral salt remains in solution form in the soil.

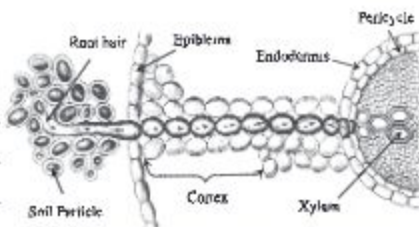

Fig. 3.6: Absorption of water by root cell through osmosis



The mineral salt remains as solute with capillary water of soil but the absorption process of water and mineral salt are different and there is no relation between the two processes. Plant cannot absorb the whole salt molecule. They absorb salt only in the form of ion. However, the salt absorption process is divided into two parts. They are 1. Inactive absorption and 2. Active absorption

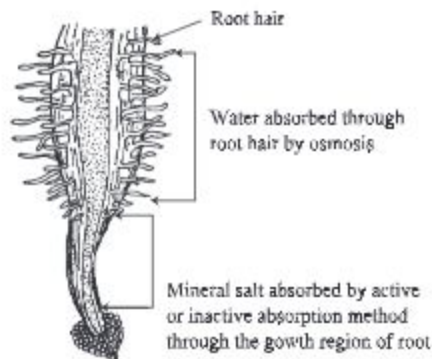

Fig. 3.7: Absorption of water and mineral salt through root.

## Lesson 6 : Transpiration

Transpiration is a special physiological process of plant. We learn from the earlier lesson that, water is essential for different physiological work of plant. For that, plant absorbs a bulk amount of water from soil through root hairs. Plants use a portion of this water in different metabolic activities and rest of it goes out in the form of vapour to the atmosphere. The loss of water in the form of vapour through evaporation from the moist surface of the internal tissues of the aerial parts of the plants, especially the leaves, is known as transpiration.

There are three kinds of transpiration, based on the outlet of the plant through which water is lost. Such as-

1. Stomata transpiration: This is the major form of transpiration.
2. Cuticular transpiration: Transpiration through the cuticle of leaves and stem.
3. Lenticular transpiration: Some water vapours go out through lenticels of the stem.

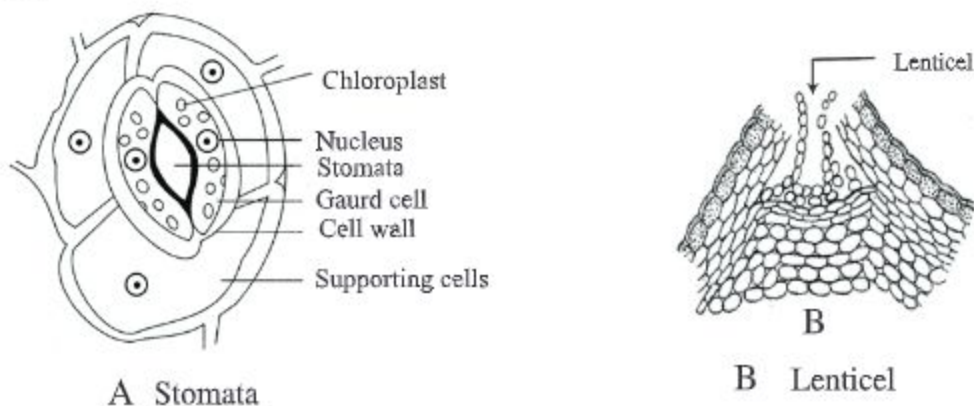

Fig. 3.8: Site of transpiration



The stomata under simple microscope and lenticels of stem in naked eyes can be seen easily.

**Activity :** Experiment of transpiration.

**Requirement :** Potted plants, table, water, polythene, thread, vaseline

**Method:** Take two plants grown in tubs, place them on the table and pour necessary water. Wrap one plant bearing leaves with polythene. Tie the polythene with the help of a thread at the base of the plant and smear vaseline over there to prevent air and water to pass. Cut all the leaves of the other plant and wrap it with polythene in the same way. Keep both the plants in the sunlight.

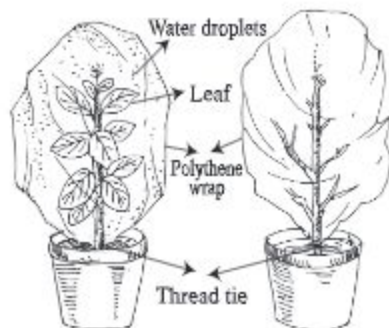

Fig. 3.9: Transpiration experiment with polythene wrap

**Observation:** After sometime you will see inside the polythene of the plant with leaves water droplets appear but they do not appear on the plant without leaves.

Why does water appear inside the polythene of the plant with leaves and not in plant without leaves? What can you prove from this experiment? What do you decide from your observation?

## Lesson 7 : Significance of transpiration

Transpiration is a very essential and inevitable process for plants. High rate of transpiration is harmful for the plants. This is why apparently transpiration is known as the 'necessary evil' for the plants. Nevertheless, transpiration is very much useful for plants because, due to transpiration, excess water is released in the atmosphere, thus decreases water pressure of the plant body. The concentration of cell sap is increased due to transpiration. This creates the right condition for endosmosis. Transpiration prevents plants from getting over heated and also maintains proper humidity of the leaves. Water is very much essential for photosynthesis, the process for manufacture of food; transpiration ensures continuous supply of water to the leaves. Due to transpiration there develops a pull into the transporting cellular tube which helps to lift the water through the xylem vessels from root to leaves through stem.

Unlike photosynthesis and respiration, transpiration shows very little effect on the environment. But in water cycle, terrestrial plants convert land water into water vapours that go out in the atmosphere through transpiration. During transpiration a huge amount of water is released in the atmosphere in the form of water vapours.

## Lesson 8-10 : Transportation of water and mineral salts

We have already known that plants absorb water and mineral salts from the soil through root hair of the root. This water and solution of mineral salts must reach the leaves because leaves mainly use these as raw materials for the manufacture of food during photosynthesis. Again the leaves send manufactured food to stem and branches. The process by which absorbed water from root hair reaches leaves and food from leaves reaches different part of the plant body is known as transportation. Like absorption, transportation process is of great importance. Transportation takes place through vascular tissue-xylem and phloem. Water absorbed through root is carried up to the leaves through xylem tissue and liquid food materials from leaves reach different parts of the plant body through phloem tissue. So vascular tissues xylem and phloem are the transporting channels of the plant body. The transporting process is carried out in the following way —

Water enters into the body through root hair by osmosis and the mineral salt dissolved in water is absorbed by inactive and active absorption and reach xylem tissue. Xylem is responsible for the upward transport of sap. Liquid food materials manufactured in the leaves go down through phloem tissue.

Upward and downward transportation is known as transportation of plants.

Water and minerals dissolved in soil water absorbed by root hair and transported to the leaves through xylem vessels can be proved by an experiment. For this we need Peperomia plant. The stem and midrib of leaf of this plant is transparent.

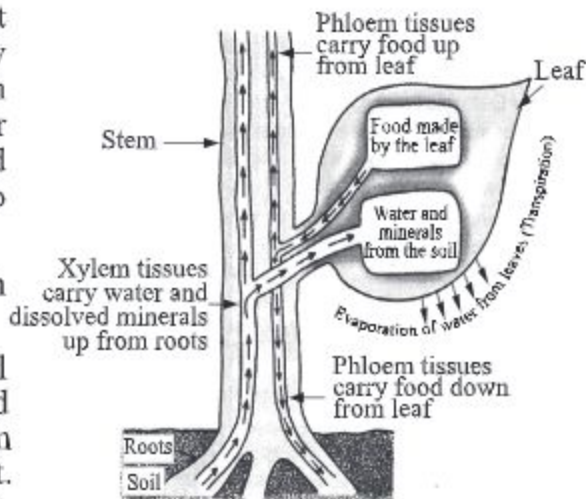

Fig. 3.10: Transportation in plant (reversible)

**Activity :** Experiment of water transportation.

**Requirements :** Dopati or Peperomia plant, bottle, cotton, red dye, water

**Method:** Uproot a Peperomia or Dopati plant and wash the root thoroughly in water. Now take a bottle and pour some water and finally drop a few drops of red dye in it. Put the root part of the plant into the bottle and set the experiment as in figure 3.11.

After a few hours it will be found that, the stem and leaf vein becomes red. Take the plant out of the bottle. Make a cross or longitudinal section and put it under a microscope and note what you have found. After the observation what would be your conclusion and what would be proved from this?

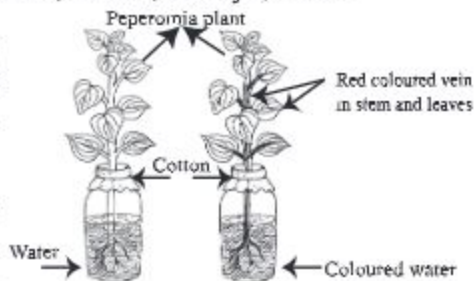

Fig. 3.11: Experiment of water transportation



**New words :** Diffusion, semi-permeable membrane, permeable membrane, endosmosis, exosmosis, ion, cell sap, active absorption, osmosis, inactive absorption, transpiration

**What we have learned at the end of this chapter**

- Process of diffusion and osmosis.
- Plants absorb water by diffusion and osmosis and mineral salts from capillary solution of the soil by active and inactive transportation via root hair.
- Water and mineral salts reach the leaves through xylem vessels.
- Phloem carries food materials from leaves to different branches and twigs.
- Water is essential for manufacture of food materials and osmosis ensures continuous flow of water to leaves.
- Transpiration creates a pull in the xylem vessels and it helps in absorption of water through root hair.

## Exercise

### Fill in the blanks

1. In terrestrial plants transpiration occurs through \_\_\_\_\_.
2. Cell membrane is a \_\_\_\_\_ membrane.

### Multiple Choice Questions

1. What do you mean by the process of release of body water of plants through leaves?
  - a. Diffusion
  - b. Osmosis
  - c. Transpiration
  - d. Imbibitions
  
2. During osmosis-
  - i. semi- permeable membrane is necessary.
  - ii. solute moves from lower concentration to higher concentration.
  - iii. solvent moves from lower concentration to higher concentration.

### Which of the following is correct?

- a. i
- b. ii
- c. i & ii
- d. i & iii



**Read the following paragraph and answer questions no. 3 and 4.**

Ms. Anowara kept some ravanigandha in the flower vase for her room decoration. In the evening she found the room was full of fragrance of flowers. She noticed similarity of this situation to a special process she has learnt in her science book.

3. What is the special process cited in the stem?
  - a. Diffusion
  - b. Osmosis
  - c. Transpiration
  - d. Respiration
4. In the cited process-
  - i. oxygen enters into the cell.
  - ii. water releases from plant body.
  - iii. plant absorbs carbon dioxide for photosynthesis.

Which of the following is correct?

- a. i & ii
- b. i & iii
- c. ii & iii
- d. i, ii & iii

**Creative Questions**

1. One day Zarif's mother kept some dried grapes (kismis) in water for cooking vermicelli. After sometime Zarif found that the dried grapes are swollen. On another side Zarif's sister was drawing a picture with the help of colour and brush. At that time a minute amount of colour from the brush drops into a glass of water and spread out in the water.
  - a. What is permeable membrane?
  - b. What do you understand by imbibition?
  - c. By which process does the dye from the brush of Zarif's sister spread out in the water? Explain.
  - d. Why is the swollen up process of dried grapes (kismis) that Zarif observed important for plants? Explain.
2. After returning from school Adiba saw that the plants in the tub had withered away. She watered the plants in the tub in the afternoon. Next morning she found all the plants alive and afresh.
  - a. What is diffusion?
  - b. Why is transpiration called the 'necessary evil'?
  - c. Why did the plants of the tub wither away? Explain.
  - d. How did the plants become alive? Explain.

**Project:** Plant a chilli/tomato sapling in a tub. Add concentrated urea solution after the sapling becomes afresh. See what changes take place in the sapling in a few days. Write down your observation and note down also the cause behind it. Discuss with your teacher what it proves. In the light of your observation what suggestions do you have for the farmers of your area?

## Chapter Four

# Reproduction in Plants

If you observe you will see a great deal of seeds is produced from a plant. From these seeds more new plants are produced. Besides, many plants are produced from different parts of plant. These all are examples of reproduction of plants.

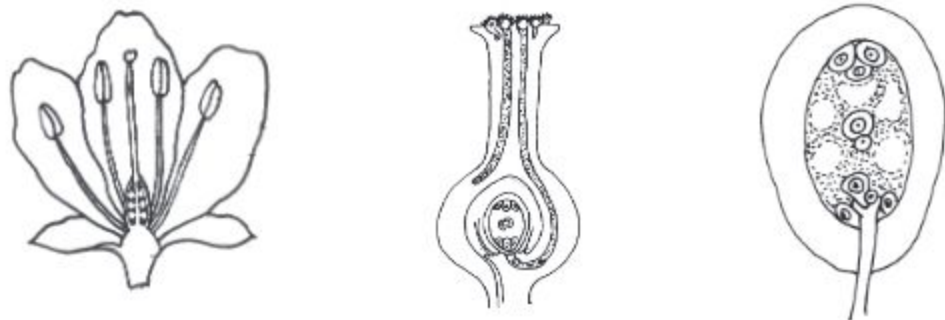

**At the end of this chapter we will be able to-**

- differentiate between sexual and asexual reproduction ;
- differentiate between different pollinations;
- identify self pollination and cross pollination in environment and explain the reason behind it ;
- explain pollinations;
- explain the process of fertilization ;
- demonstrate germination through experiment.

### Lesson 1-3 : Reproduction

Every organism of the world tends to keep its descendants before it dies. This is a natural phenomenon. The complex process by which an organism produces its offsprings is known as reproduction. It is of two categories. One is sexual reproduction while another is called asexual reproduction.

#### Asexual reproduction

Asexual reproduction is a mode of reproduction by which offspring arise from a single parent, and inherit the genes of that parent only; it is reproduction which does not involve meiosis, fertilization. The offspring will be exact genetic copies of the parent. Asexual reproduction is mostly found in lower graded living beings. Asexual reproduction is of two types; for example, spore production and vegetative reproduction.



- (a) **Formation of spores:** The tendency of asexual reproduction by spore production is found mainly in lower graded plants. The modified somatic cells of the plant body produce organs which contains spores. These are known as spore case (sac) or sporangium. A fully formed sporangium generally bears numerous spores. But sometimes sporangium bears a single spore. Spore may develop outside the sporangium. These are known as exospores. Some exospores are known as conidium. *Mucor* reproduces asexually by forming enormous numbers of microscopic spores inside sporangium. *Penicillium* reproduces by formation of conidia.
- (b) **Vegetative reproduction:** Asexual reproduction takes place by vegetative structure i.e. without formation of spore or gamete. This type of reproduction is known as vegetative reproduction. In that case any organ may be modified or the fragmentation of any portion of the body may occur. When the vegetative reproduction occurs in natural way or spontaneously, it is called natural vegetative reproduction. When it occurs artificially, then it is called artificial vegetative reproduction.

**Natural Vegetative reproduction:** Vegetative reproduction that takes place naturally by different methods.

1. **Segmentation:** Generally this type of reproduction is seen in lower plants. For example, if fragmented each part of *Spirogyra*, *Mucor* etc. grows into a new plant and live independently.
2. **Through root:** Some plants are grown from the roots. Example- Segun (tick), Patol, etc. Some roots are fat and juicy. Buds are grown on the surface and from these buds new plant grows. Example-Sweet potato.
3. **Modified stem:** You must know which part of the plant body is known as stem. In some cases stems are modified. Some of these modified stems have no resemblance with true stem for their appearance and positions. This modification occurs in order to protect from adverse condition, to ensure storage of food or for vegetative reproduction. These modifications are given below-
  - (a) **Tuber:** Stem tubers are formed by outgrowths from the lowest axillary buds which turn downwards into the soil. Eventually the tip of the underground stem fills with starch and swells rapidly to form a tuber. Tubers are distinguished by their origin and the presence on their surfaces of scale leaves and axillary buds, which form the eyes. From each eye an individual plant grows. For example- Potato.

**Task:** Show how vegetative reproduction takes place in potato and ginger.



- (b) **Rhizome:** Rhizome lies inside the soil parallel of land. Like stem it bears distinct node and internode. Internode bears scale leaves and auxiliary buds. They become fattening and juicy by storing food. In favourable condition these buds grow into individual plants. For example-Ginger.
  - (c) **Bulb :** These are very small stems. New plants grow on their axillary and terminal buds. Example-Onion, Garlic etc.
  - (d) **Stolon:** You may have seen arum stolon. These are branches from arum (kochu) and modified for reproduction. Stolon produces buds at the terminal end and thus helps in reproduction. Example-Arum, Minit (pudina).
  - (e) **Offset:** Water hyacinth, Spirodela etc. form a very short runner called an offset. Runners grow out horizontally from axillary buds forming several new plants. After some days the daughter plants are detached from mother plants and grow individually. Example- Water hyacinth.
  - (f) **Bulbil:** The improper development of auxiliary buds of some plants forms round-shaped structure called bulbil. After sometimes, bulbil is separated from the plant and drops on soil and finally produces new plants. Example-Yam.
4. **From leaves:** From a grounded leaf of a Bryophyllum numerous young bryophyllum grows. Example-Stone-chips (Bryophyllum). All the process of vegetative reproduction cited above occurs naturally. The daughter plant that grows from vegetative reproduction has the same characteristics as the parent. So, no new character appears. So, for production of better quality cash crops, artificial vegetative propagation method is used.

**Artificial vegetative reproduction:** You have seen the grafting of good variety of mango, orange, lemon, guava etc. Can you say why we do grafting? Plants produced from seeds sometimes show less productivity and inferior quality. In these plants artificial vegetative propagation is a useful tool to restore the parental quality. Let us know about artificial vegetative propagation.

1. **Grafting:** The process by which a straight, young and fresh stem develops root and thus enables the stem to live individually is known as grafting. A cut is made in the bark of the stem, where roots to be developed. Now the cut is to be covered by soil and cow dung, and finally with the help of cellophane tape or polythene to protect the fall off soil and cow dung. This part of the stem should be kept moist by regular watering. If kept in this condition, root will grow in a couple of days. The stem with root, separated from mother plant, grows into new plant after planting.
2. **Cutting:** You have observed that stem cuttings of rose if put into moist soil grows new leaves after a few days. Each stem of this kind grows into a new rose tree.

**Task:** Take a rose stem and show how stem grafting or cutting is made.

## Lesson 4 : Sexual reproduction

Fruit grows from flower and seed from fruits. Seed gives rise to the next generation. A flowering plant produces offsprings through sexual reproduction. So, flower is an important organ of plant.

**Flower :** There are many flowers blooming near your school and house. First you take some flowers among it and observe carefully. Have you seen total five parts in every flower? The parts are receptacle, calyx, petal, stamen (androecium) and carpel (gynoecium). If you get all those parts then the flowers are known as typical flower or complete flower and you do not get one or two parts then the flowers are known as incomplete flower. Some flowers may have extra parts under the calyx, such as china rose (joba). This extra parts is called epi-calyx.

Some flowers may or may not have stalks (pedicel). Flower with stalk is known as stalked and without stalk is known as unstalked flower.

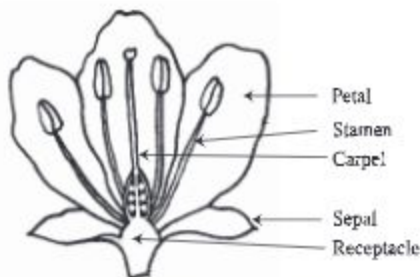

Fig. 4.1: Different parts of a typical flower

### Different parts of a flower

**Sepals:** In many flowers there is an outermost whorl (ring) of sepals, known collectively as the calyx. Sepals are usually green and look like small leaves. Sepals may be segmented or joined. They enclose and protect the central region of the flower (from sunlight, rains and insects) when it is in its budding stage.

**Petals:** In most of the flowers the reproductive organs are surrounded by a whorl of petals. Petals are known collectively as the corolla of the flower. Petals may be joined as in datura or may remain separated, eg, china rose. Some flowers have different coloured and scented petals. Petals of this type attract insects which come to collect the nectar and by doing so transfer pollens from flowers to flowers. This is the second whorl of the flower.

**Stamens:** Surrounding the gynoecium is a whorl of stamens. Stamens are known collectively as androecium. These are the male reproductive organs. A stamen consists of a stalk (filament) bearing an anther. Each anther is made up of four pollen sacs in which pollen grains are formed. Pollen grains contain the male gametes. They take part in reproduction directly. This is the third whorl of the flower.



**Carpels:** The gynoecium is at the centre of a flower. A gynoecium may be structured with one or more carpels. When a gynoecium is formed with many more carpels which are completely merged with each other, then it is called, syncarpous and when they are separated, it is called polycarpous. The gynoecium is typically made up of an ovary, style and stigma as in the centre of flower. One or more ovules are in a flower, arranged inside the ovary. Within the ovule, the female reproductive cell ovum is produced. This ovum, like an androecium, is directly involved in the process of reproduction.

**Task:** Collect a china rose and a datura flower. Separate different parts and show them to the class.

Sepal and petals are known as the accessory whorl while the stamens and carpels are known as the essential whorl of a flower.

**Thalamuth and the Flower-sheet:** This section holds all the above tuft.

### Inflorescence

You all have seen inflorescence. The mode of arrangement of flowers on the floral axis is known as inflorescence. The inflorescence is of two types. For example-

- (a) Racemose-The growth of the floral axis is unlimited.
- (b) Cymose-The growth of the floral axis is limited.

Inflorescence is very important for pollination.

## Lesson 5 - 6 : Pollination

Pollination is also known as pollen transfer. Pollination is the precondition of fruit and seed production. Rub your finger on the stamens of androecium of a flower and observe. A kind of yellow or orange coloured powder must stick to your finger. These powders are pollen or pollen grains.

Pollination is the transfer of pollen grains from anthers to stigmas. Pollination is of two types-self pollination and cross pollination.

**Self pollination:** Self pollination is the transfer of pollens from anthers to stigmas in the same flower or between flowers on the same plant. Example- Mustard, Pumpkin, datura etc.

**Cross pollination:** Cross pollination is the transfer of pollens from one plant to the stigmas on another plant of the same species. Shimul, Papaya etc. show cross pollination.

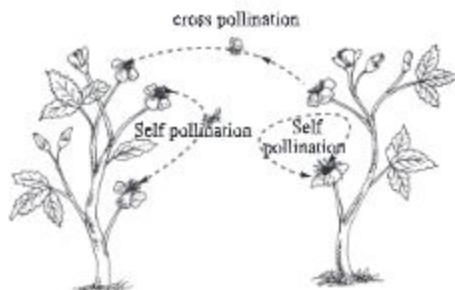

Fig. 4.2: Self-pollination and cross-pollination



**Agents for pollination:** In most cases the transfer of pollen occurs through an agent. The carrier that carries pollen up to stigmas is known as agents for pollination.

Wind, water, insects, birds, snails as well as man also act as agents of pollination. Insects and birds fly from flowers to flowers in search of nectar or in attraction of their brilliant colours. During this act pollen grains get stuck to the body of the carrier. As insects and birds do this, they transfer pollen from one flower to another unknowingly.

To get the help of pollinating media some structural modifications are seen in flowers. These modifications are known as adaptation. The adaptations are different for various pollinating media. The adaptations are as follows-

**Adaptation of insect-pollinated flowers:** Flowers, large, brightly coloured and scented petals with nectars. Pollen grains and stigmas are sticky. Example- China rose, Pumpkin, Mustard etc.

**Adaptation of wind-pollinated flowers:** These flowers do not have scent, nectar or coloured petals. They are small. Stigmas are sticky, branched and sometimes feathery. Anthers are on long stalks. For example-Paddy.

**Adaptation of water-pollinated flowers:** Flowers are small, light-weight and can float in water. These flowers do not have scent. Female flowers have long stalks whereas male flowers are with short stalks. Matured male flowers get detached from stalks and float on water.

**Adaptation of animal-pollination flowers:** These flowers are moderately large. If small they arranged in inflorescence. Brightly coloured, may have scent or not. Example- kadom, shimul, arum etc.

## Lesson 7 and 8 : Fertilization and fruit formation

Formation of gamete is the precondition of fertilization. The sexual union of the motile and small male gamete with the comparatively bigger, non - motile female gamete is known as fertilization.

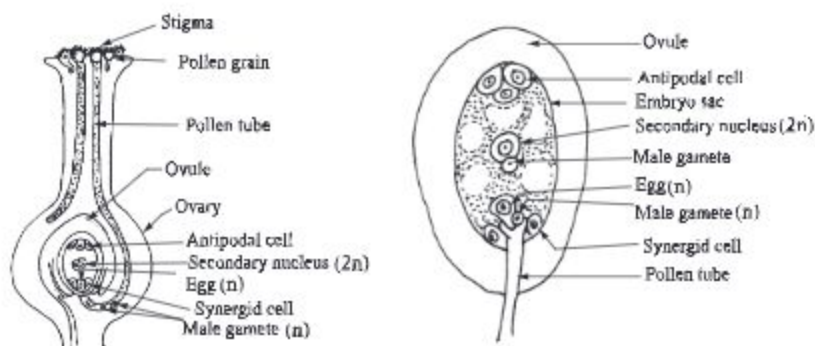

Fig. 4.3: The process of fertilization

Pollen grains are transferred to the stigma by pollination. The stigma produces a sticky fluid which nourishes the pollen grains and stimulates each other to burst open and develop a long, hollow, tubular outgrowth known as pollen tube. This tube pushes its way between cells of the style and grows towards the ovule and finally reaches the embryo sac.

By this time, two male gametes are formed inside the pollen tube. The apex of the pollen tube ruptures (bursts open) releasing male gametes. Ovule contains embryo sac. Female gamete or ovum develops inside embryo sac. One of the two male gametes discharged from the pollen tube unites and fertilizes the egg. The other male nucleus (gamete) unites and fuses with secondary diploid nucleus and develops into cereal grains.

**Formation of fruits:** Mango, Jackfruit, Litchi, Banana, Grape, Apple, Guava, Safeda etc. are considered as fruits. These fruits may be eaten without cooking. Vegetables like Gourd, Pumpkin, Ribbed gourd (jhinga), Palwal (patol) etc. that we eat after cooking are also fruits. In fact these all are fruits. The process of growing these fruits start by the transformation of ovaries of gynoecium of flower. The transformation occurs in the ovary after pollination and fertilization. The ovules transform into seeds. After fertilization, the ovary alone or in combination with other floral parts turns into fruits.

When only the ovary turns into fruit, it is known as true fruit, eg, Mango, Jackfruit etc. When the fruits are developed from different floral parts other than the ovary, they are called false fruit, eg, Apple, Dellenia (chalta) etc. All (both true and false) fruits are divided into three main classes on the basis of their origin and nature. These are - simple fruit, aggregate fruit and multiple fruit.

- (1) **Simple fruit:** When the ovary of a single carpel or more than one united carpels of a flower develop into a fruit, it is known as simple fruit, eg, Mango. Depending on the nature of pericarp, simple fruits are again divided into two groups- dry fruits and fleshy fruits.

**Dry fruits:** Fruits having thin and dehiscent pericarps when they are ripe, are known as dry fruits. Example- Bean, Lady's finger, Mustard etc.

**Fleshy fruits:** Fruits with thick and succulent pericarps are known as fleshy fruits. The pericarp of fleshy fruit does not split open when it ripens. Example- Mango, Black berry, Banana etc.





Fig. 4.4: Simple fruit



Fig. 4.5: Aggregate fruit



Fig. 4.6: Multiple fruit

**Aggregate fruit:** When the fruit develops from the merger of several ovaries with many free carpels of a flower, it is known as aggregate fruit. The number of fruitlets formed corresponds with the number of carpels present in the gynoecium of the flower. A cluster of fruitlets is produced at a time and placed on a single stalk. For example -Custard apple, Champa, Nayantara, Akanda etc.

**Multiple fruit:** When all the flowers of an inflorescence together form a fruit, it is known as multiple fruit. Examples of such fruits are- Pineapple, Jackfruit etc.

**Task:** Collect some fruits and write down their types in your notebook.

### Lesson 9 - 10 : Structure of seeds and its germination

**Structure of seeds:** Place a filter paper inside a bowl and soak it with water and then put 8-10 wet gram seeds on it and keep it covered for 3-4 days. They will germinate. There is a small pore, called micropyle, near the pointed part (end) of the seed. Radicle comes out through it. Seed at this stage may be pelled off by slight pressing of the finger tips. Felled off seed is yellow in colour. Two cotyledon of the seed will be open if further pressure is applied to it. At the junction of two cotyledon there is a white coloured structure, known as embryonal axis.

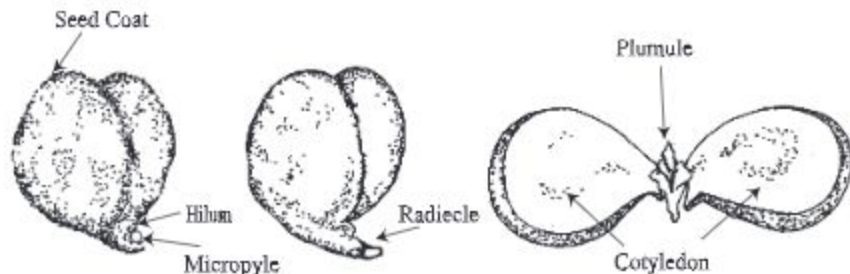

Fig. 4.7: Different parts of a gram seed.



The area of embryonal axis which is attached to the cotyledons is known as nodal zone. The part of embryonal axis above the nodal zone is called epicotyle and the part below the nodal zone is known as hypocotyle. The upper apex of the embryonal axis is known as plumule while the lower end of embryonal axis is called radicle. Radicle, plumule and cotyledon are collectively known as embryo and their outer covering is called seed coat. Seed coat consists of two layers, such as-

**Outer layer:** The outermost layer of seed coat is hard and thick. It is known as testa.

**Inner layer:** The innermost thin layer of seed coat is known as tegmen.

**Task:** Show different parts of a pea seed through an experiment.

**Germination:** The development of a seedling from a seed is called germination. In order to germinate, seed requires water, warmth and air. The germination in which the epicotyle grows up rapidly and as a result, the plumule comes out of the soil leaving the cotyledons underground, is known as hypogeal germination. This type of germination takes place in gram, paddy, mango etc. Sometimes plumule with cotyledons come out of the soil, it is called epigeal germination. Tamarind, Castor, Pumpkin etc. shows this type of germination.

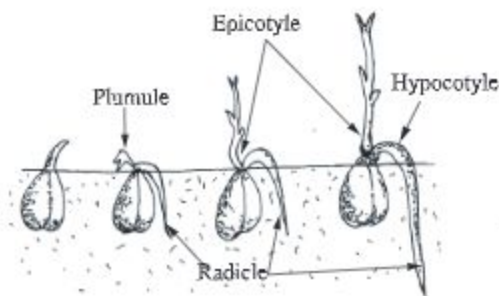

Fig. 4.8: Hypogeal germination

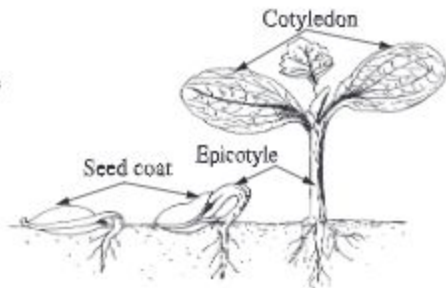

Fig. 4.9: Epigeal germination

**Germination of gram seed:** Here hypogeal germination takes place. In this type of germination plumule comes out of the soil leaving the cotyledons underground. Excess growth of epicotyle is responsible for this. Gram is a non-endospermic dicot seed. After sowing gram seeds and soil is supplied with required quantity of water, temperature and air, they germinate and come out of the soil in 3-4 days. Firstly, the seeds swell up by absorbing water and radicle comes out through micropile. Gradually, it develops into tap root. In second step plumule comes out of the soil. In this case the two cotyledons remain under the soil. Initially, embryo gets nourished by the food stored in the cotyledons.

**New words :** Asexual and sexual reproduction, spore, tuber, rhizome, bulb, bulbil, hypocotyle, epicotyle, tegmen

**What we have learned at the end of this chapter**

- Reproduction is mainly of two types, for example, asexual and sexual.
- Flower is the reproductive organ of higher plants.
- An ideal flower has five parts.
- Fruit is mainly of three types, eg, simple, aggregate and multiple.
- Germination is of two types. For example, hypogeal and epigeal.

## Exercise

### Fill in the blanks

1. Reproduction is mainly of two types, \_\_\_\_\_ and \_\_\_\_\_.
2. When fruit develops from single ovary, the fruit is called \_\_\_\_\_.
3. The flower which bears \_\_\_\_\_ part, is known as complete flower.
4. Pollination is of two types \_\_\_\_\_ and \_\_\_\_\_.
5. When all the flowers of an inflorescence together form a fruit, it is known as \_\_\_\_\_ fruit.
6. Ovule of the matured fruit develops into \_\_\_\_\_.

### Short Answer Questions

1. Why asexual reproduction is important for plants?
2. Why grafting is made from mango tree?

### Multiple Choice Questions

1. Which one of the following is aggregate fruit?
  - a. Mango
  - b. Custard apple
  - c. Jackfruit
  - d. Pineapple

2. Which one is the characteristic of insect- pollinated flowers?
- a. They are colourless
  - b. They are scentless
  - c. They are very light
  - d. They are colourful and bears nectargland.

From the figure below answer questions no. 3 and 4

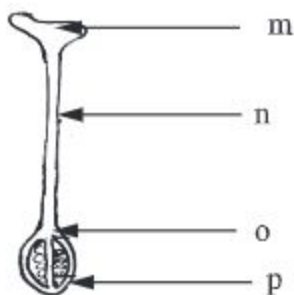

3. Which part receives pollen grains?
- a. m
  - b. o
  - c. n
  - d. p
4. p part of the figure-
- i. develops into fruit
  - ii. develops into seed
  - iii. helps in reproduction.

Which one of the following is correct?

- a. i & ii
- b. i & iii
- c. ii & iii
- d. i, ii & iii

**Creative Questions**

1.



M



N



O



P

- a. What is reproduction?
- b. What do you mean by pollination?



- c. Draw a labelled diagram of the longitudinal section of the plant part constituted by M, N, O and P parts.
- d. Of M, O and P, which two parts are more essential for plant reproduction? Give reasons in favour of you answer.

2.

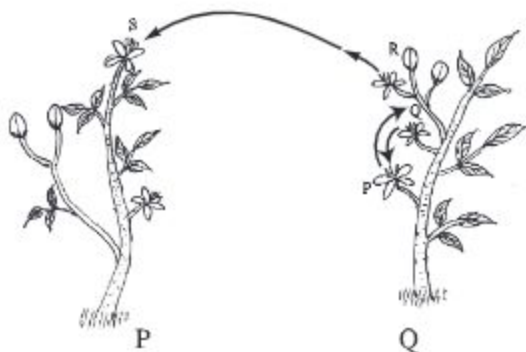

- a. What is vegetative reproduction?
- b. What do you mean by germination?
- c. Explain pollination between P and Q flower.
- d. Which pollination of the two figures play role in creating new characteristics? Give your comments after having a comparative analysis.

### Do yourself

1. Collect gourd, pumpkin, datura, brinjal, kolke flower, china rose and bean flower and examine which of these flowers have five parts.
2. Take a tamarind seed and examine its germination. Note down the changes.

## Chapter Five

# Co-ordination and Secretion

Co-ordination is very important for living organisms. Like animals, plants also need co-ordination among their different functions. Growth, reproduction, sensitivity and reflex action etc. are the characteristics of living organisms. Hormone plays essential role in doing these functions. Unlike animals, plants have no specialized system. Except lower animals, all higher animals have specialized system for performing different physiological activity of the body. The co-ordination and integration among different organs of the body and to respond to stimuli in order to keep harmony with the environment are the main function of nervous system.

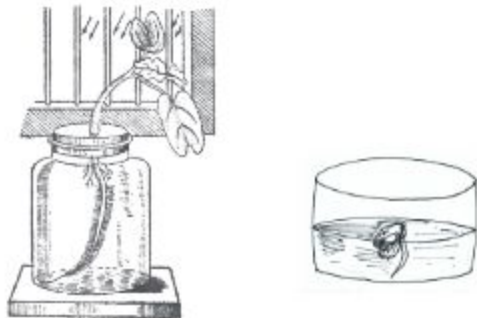

**At the end of this chapter, we will be able to–**

- explain co-ordination in plants and human;
- explain the function of nervous system with a flow chart;
- explain with example the stimulating activity of plants;
- explain with example the stimulating activity of human;
- explain the excretion of plants and animals.

### Lesson 1-3 : Co-ordination in plants

Inside each plant cell, different physiological activities occur under some rules and regulations. So, co-ordination is an essential activity of the organism. In absence of this co-ordination, life of living beings will be disorganized. Different stages of life cycle of a plant, such as- germination, flowering, fruit formation, decaying, dormancy etc. maintain an order. The influence of weather and climatic factors are notable here.

Different physiological activities of plants, including growth and movement, are performed systematically following some specific orders. One activity does not hamper another activity. Scientists tried to know how plants co-ordinate all these activities. They opined that growth and development, origin of different organs etc.

of plants are controlled by some intrinsic secretion of plants. This organic compound is known as phytohormone or growth regulating substance. It controls all the physio-chemical activity of the plant. Plant hormones are the natural growth substances, which are usually synthesized in one part of a plant and are translocated to other parts where they exert their influences. Hormones found in plants are- auxins, gibberellins and cytokinins which enhance growth. Abscisic acid and ethylene acts as growth retarding agents. Florigen is synthesized in leaves and translocated to leaf base(stalk) and it transforms buds into flower buds. So, it is found that florigen influences on the initiation of flowers.

**Auxin:** Charles Darwin first discovered this hormone. He observed the effect of light on the plumule membrane. When light falls obliquely on one side, the plumule grows towards the light source by bending gradually. In fact, the substance of the apical part of the plumule was a growth hormone auxin. Auxins can induce adventitious roots in stem cutting and plays an important role in inhibiting the process of abscission of fruits.

**Gibberellin:** It is found in seedlings, cotyledon and growing parts of leaves. Due to its effect the internode of the plants elongate. For this reason, when applied to a dwarf plant it grows in height. Gibberellins are known to overcome the dormancy of seeds.

**Ethylene:** This gas has been found to be very significant as it is produced by almost all the fleshy fruits during the process of ripening. For this reason, ethylene is now regarded as a gaseous phytohormone. This hormone is also present in fruits, flowers, seeds, leaves and roots. Ethylene can eliminate the normal geotropic responses of seedlings and consequently deformed seedlings are produced.

**Movement:** Like other living organisms, plants also have sensitivity. Due to this, effect of internal or external stimuli on plant body creates sensation and consequently plant moves and grows. This type of movement is known as tropic movement.



### Experiment on phototropism of plants

**Requirements:** A transparent bottle with wide mouth, nutritive solution, cork with a hole, a fresh seedling.

**Experiment:** Take a bottle and filled it with nutritive solution, put its cork and place the seedling through the hole in such a way that the roots remain submerged under nutritive solution. Now keep the bottle on a window sill.

**Observation:** After four or five days it will be observed that the stem and leaf stalks respond by growing towards the light i.e. they bend so that the leaves face the light. The roots bend in opposite direction of the light source.

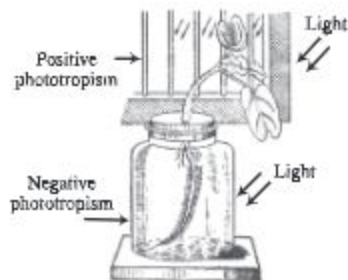

Fig. 5.1: Plant responses to light.

**Inference:** From this experiment it is proved that the stems generally show a curvature towards the source of light but the roots grow away from the source of light.

**Task:** After discussion with your teacher set an experiment to verify that gravity affects the growth of plant.

**Use of hormone:** Auxin and other artificial hormones induce root in stem cutting. Indole acetic acid (one type of auxin) helps in repair of wear and tear. Application of auxin delayed abscission of fruits. Different stimuli like light, water, gravity etc. influence the growth of plants.

### Lesson 4 - 5 : Nervous system

In class six you have known from classification, the characteristics of unicellular and multicellular organisms. There are different structures of tissue, organ and organ system etc. in multicellular organism. In different organs, there is an assemblage of various functions of numerous cells. To coordinate with these functions and to keep harmony with the environment body needs quick coordinating system. Such as- someone's evil news makes you cry but good news makes you cheerful, your good result in examination makes you delightful. Various stimuli provokes all these activities. To carry stimuli from different parts of the body, coordinate the activities of the different organ systems of the body and to keep harmony with the environment are the main functions of nervous system.

The system of animal body which maintains communication between different organs, coordinates the functions of all other systems and respond to stimuli in order to keep harmony with the environment is called the nervous system. Brain is the main part of the nervous system. The brain of man is the most developed one amongst all animals and man is therefore known as the best creature of the universe. Brain is formed by numerous specialized cells called neurone or nerve cell.

### Nerve cell or neurone

The structural and functional unit of nervous system is the neurone. A neurone is the longest cell of the human body.

A typical neurone is mainly divided into two parts, namely- 1. Cell body and 2. Processes.

**1. Cell body:** The cell body is the main part of the neurone. The cell body may be of different shapes, for example, round, oval or star-shaped. The cell body is composed of cell membrane, cytoplasm and nucleus. Nerve cells have no centriole, so they cannot divide like other cells.

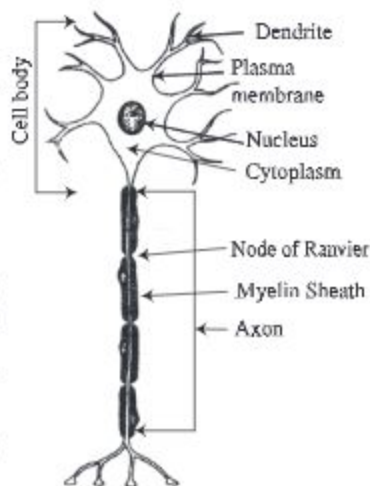

Fig. 5.2: Neurone

**2. Processes:** The branched, tree like structures that extend from the cell body are called processes. The processes are of two types, such as - (a) Axon and (b) Dendron.

**a) Axon:** The long, thread like structure originated from the cell body is called axon. There is usually only one axon per neurone. The end (opposite to the cell body) of an axon breaks up into many fine branches.

**b) Dendron:** The branched structures originated around the cell body are termed as dendron. They are small, relatively wide, and breaks up into fine terminal branches called dendrites. They conduct impulses towards the cell body.

**Synapse:** The junction between the two neurones where axon of one neurone ends and the dendrons of another neurone arises known as synapse. Synapses allow information to pass from one neurone to another.



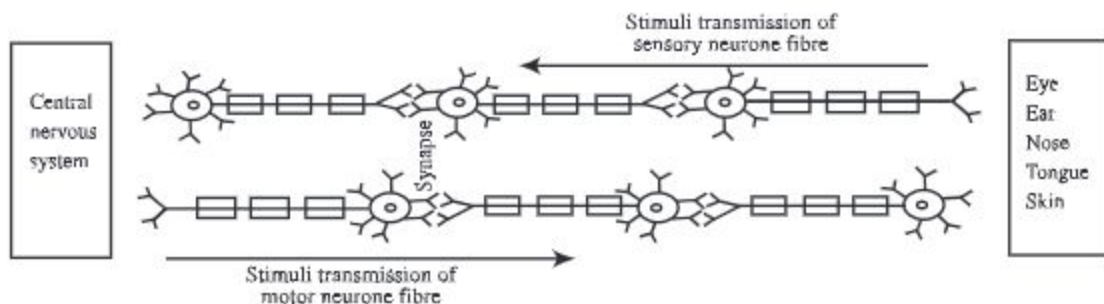

Fig. 5.3: Flow chart of the transmission of an impulse of the nervous system.

To carry stimuli, to maintain communications between internal and external environment of the body, coordinate the activities of different organ systems of the body, retain memory and to think and pass instructions for work are the functions of neurone. The transmission of impulses through the synapses of nervous system (neurone) are shown in the figure.

The nervous system consists of mainly three parts, namely, (1) Central nervous system (2) Peripheral nervous system and (3) Autonomic nervous system.

## Lesson 6 - 7: Brain

### Central nervous system:

The central nervous system consists of brain and spinal cord. Brain is the sole controlling agent of the whole nervous system. Human brain is contained and protected within the skull. Brain is covered by three layers of membranes called meninges. Human brain has three major parts - (1) Cerebrum (Fore brain), (2) Mid brain and (3) Hind brain.

**1) Cerebrum:** The cerebrum is the main part of the human brain. It consists of two incompletely divided lobes, the right and the left cerebral hemisphere (lobe). The two hemispheres are connected to each other by broad tract of nerve fibres. The human cerebrum is comparatively more developed than in any other animals. The exterior surface of the cerebrum, the cerebral cortex, is a convulated, or folded, greyish layer of cell bodies or neurones known as the grey matter. The grey matter covers an underlying mass of fibres or axon called the white matter. Only nerve fibres or axons are present here and no cell body is found. As the nerve fibres are white in colour, the layer beneath the cortex is known as white matter. Grey matter has many layers of nerve cells. These nerve cells, by accumulation, forms nerve centre in different parts of the cerebrum. These centre acts as functional site for specialized activities. Vision, hearing, smell, thinking, memory, knowledge, conscience, intelligence, and movement of muscles are controlled by these nerve centre.



The lower part of the cerebrum constitute the thalamus and hypothalamus. These are the collection of grey matter. Anger, shame, hot, cold, sleep, temperature regulation and movement of the body are controlled by this region.

**2) Mid brain:** The area between cerebrum and pons is called mid brain. It acts as centre for auditory and visual reflexes.

**3) Hind brain:** It is located at the lower back of the cerebrum. It is smaller than cerebrum. The main function of the hind brain is to maintain the balance of the body. It also controls speech and movement of the body. The hind brain consists of three parts-

**Cerebellum:** Cerebellum is located at the back of the brain and behind pons. It remains suspended. Cerebellum is divided into right and left part.

**Pons:** It is located in front of and under the cerebellum, connecting medulla oblongata with the upper parts of the brain.

**Medulla oblongata:** The long stalk-like lowermost portion of the brain stem is called the medulla oblongata. Starting from the lower end of pons the medulla oblongata extends up to spinal cord. It connects the brain with the spinal cord. So, it is called the stalk of the brain. Medulla oblongata controls various reflexes like breathing, swallowing, heart beat etc.

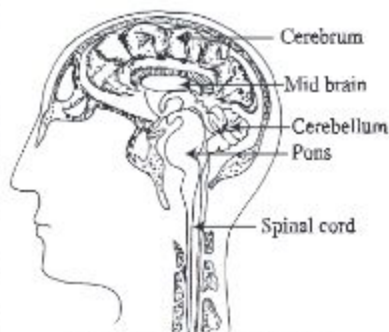

Fig. 5.4: Structure of brain

**Task:** Look at the chart and draw the figure of brain. Write the function of different parts besides the located part of the picture.

### Lesson 8-10 : Spinal cord

The spinal cord is protected by vertebral column. In spinal cord the positions of grey matter and white matter are reversed i.e., grey matter inside and white matter outside. A large number of nerve fibres (sensory and motor) ascend or descend along the white matter of the spinal cord.

#### Reflex action

What will you do when a mosquito sits on your hand? You must try to kill the mosquito. How do you feel that mosquito is on your hand? You feel mosquito bite, so you do so. You feel mosquito bite through nerve impulse and your response to this stimulus is also due to nerve impulse. The mirror reflects light instantly when it receives light, reflex action is also like that.

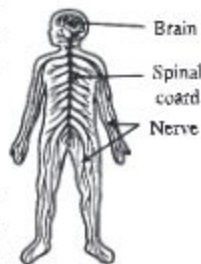

Fig. 5.5: Human nervous system

Reflex action is the consequences of immediate action of nerve impulse. What is the nerve impulse? Information, in the form of electrical impulses, flows through the nerve cell is called the nerve impulse. When a mosquito sits on our hand, we drive it away or when a pin pricks our hand or feet we withdraw our hand or feet immediately. How it happens? The presence of mosquito on the hand stimulates a sense organ. This sensation travels from the sense organ to the spinal cord through sensory nerve fibres. In response, the central nervous system sends back a message through motor nerve fibres to the muscle of hand and as a result we drive away or kill the mosquito.

Reflex action occurs automatically (spontaneously) without conscious thought. It may be defined as the inborn, automatic actions of the body which are done without the involvement of thinking or brain. Thus these actions are immediate and spontaneous and may be described as automatic response to stimuli. Reflex actions are usually conveyed through spinal cord by a path called reflex arc. A reflex arc has the following constituents: (1) receptor (sensory organ) (2) sensory (afferent) nerve (3) interneurons (4) motor (efferent) nerve and (5) effector organ.

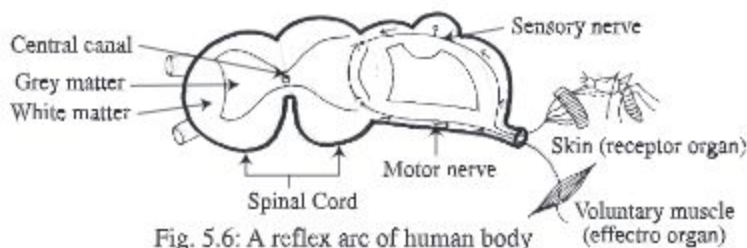

Fig. 5.6: A reflex arc of human body

**Explanation:** Immediately after the pin pricks the skin of our hand, the sensory organ (receptor) perceives the stimuli of pain; this painful stimuli passes into the spinal cord through sensory (spinal) nerves; interneurons transmit the impulse from afferent neurones to efferent neurones; the motor nerve carries the message from spinal cord to the muscles; the effector organ shows response to the stimuli and consequently muscle contracts and we withdraw our hand from painful stimuli.

It is very important to realize that figure 5.6 is a greatly simplified picture of a reflex action. In a reflex action, first a sense organ is stimulated by a pin prick. This sensation travels from the sense organ to the spinal cord through the afferent or sensory nerve fibers. In response, the central nervous system sends back a message through the efferent or motor nerve fibers to the muscle of the organ and as a result, the organ is withdrawn.



Apparently the simple reflex action is in fact very complex events. The nerve fibres conduct impulses from the sensory side of a reflex arc to the brain, and other fibres conduct impulses from the brain to the opposite side of the spinal cord. These connections with the brain enable a person to be aware of certain spinal reflexes and up to a point, exert control over them. Reflex action is a combined act. In absence of any of the five parts, which makes reflex action effective, it cannot work properly.

**Task:** What will you do if a pin pricks your hand or if you touch a hot chimney of a lantern (Hurricane)? Why do you do so? How do you do so? Explain it with a diagram.

### Lesson 11- 12 : Excretory system

Through nose we take and expel air. We sweat during excess heat. These are all excretory products. What is an excretory product? Excretory products are those substances which are harmful and unwanted for the body. Excretion is the process by which organism removes harmful, unwanted waste products from the body. Water, carbon dioxide, urea etc. are the waste products of metabolism of human. The regular removal of these waste products are necessary because, if they are accumulated, they would affect the metabolic activities. Moreover, they are toxic and their retention in the body may cause intoxication and even death of the organism. These waste products are expelled from the body mainly through expelled air, sweat and urine. Lung, skin and kidney are the three main organs of excretion. Lung eliminates carbon dioxide and skin eliminates harmful salt substance from the body. The liquid nitrogenous waste products of the body are excreted through kidney.

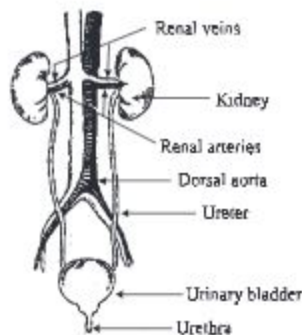

Fig. 5.7 : Excretory System

Waste products from the body are removed by kidney, skin and lungs. 80% of the total nitrogenous excretory products are eliminated as urine from the body. So, kidney is termed as the main excretory organ of the body. The system which performs the function of excretion is called excretory system.

**Activity :** Observing the presence of carbon dioxide in breath.

**Requirements :** Test tube, glass/plastic pipe, lime water

**Method :** Take some clear lime water in a test tube. Put a plastic pipe or glass pipe in to the test tube. Now blow air through the pipe. Observe what happens. After blowing air for sometime, you will see that the lime water becomes turbid. Why it happens?

We know, carbon dioxide make lime water turbid. From this experiment it is proved that the air we breathe out contains carbon dioxide.



A small/tiny amount of carbon dioxide is not injurious to health. But a large amount of carbon dioxide is toxic, which is injurious to body. Our body cell produces this gas as by product, during respiration. Blood carries carbon dioxide from cells to lung. The exhaled (breathing out) air contains 4% carbon dioxide. It also contains water vapour and carbon dioxide.

**Activity :** Observing the presence of water vapour in breath.

**Requirements :** A piece of glass or a mirror

**Method:** In a winter morning keep your mouth in front of a glass plate or mirror and exhale air through mouth (not nose). What do you see on the glass? The exhaled air contains carbon dioxide and water vapour. The water vapour produces water droplets on the cold glass and the mirror or glass plate becomes rather turbid and somewhat opaque. After sometimes water droplets evaporate from the mirror and the mirror becomes transparent again.

We see from this, the exhaled air contains water vapour.

### Sweat

The outer layer of human body is known as integument or skin. Skin bears numerous tiny pores. These are hair follicles. Sweat comes out through this hair follicle. Sweat contains water, salt and a small amount of carbon dioxide. Besides, there are some other harmful or useless substances in the sweat.

### Urine

Kidney is termed as the factory of urine production. They lie at the back of the abdominal cavity, one on each side of the vertebral column just below the diaphragm. Kidney acts as filter. During the breakdown of excess amino acids in the liver, nitrogenous waste products like ammonia, urea and uric acid are formed. These are harmful for the body. The kidney extract these harmful substance from blood, and excrete it from the body as part of a liquid called urine. Urine is a transparent, pale-yellow coloured aqueous fluid.

Urine is retained in the urinary bladder for a particular period of time. During filling of the urine, the urinary bladder expands. When sufficient pressure is mounted inside the bladder, a spontaneous nervous activity (reflex) is initiated so that the smooth muscles of the bladder wall contract and the urethral sphincters are relaxed. As a result, the urine flows out from the bladder through the urethra.

**New words:** Auxin, hormone, gibberellin, ethylene, cytokinin, neurone, axon, dendrite, synapse, cerebrum, grey matter, white matter, pons, medulla, oblongata, motor nerve, sensory nerve, reflex arc, reflex action

**What we have learned at the end of this chapter**

- Centriole is absent in neurone.
- The structure of neurone is different from those of the somatic cell.
- A junction between the two neurones where axon of one nerve cell ends and the dendron of another nerve cell arise is known as synapse. Nerve cell transmits impulse from one nerve to another through this synapse.
- The grey matter of cerebrum has many layers of nerve cells. These nerve cells form clusters at different regions and places of cerebrum. These clusters of nerve cells are called nerve centre.
- In the spinal cord, grey matter forms the central core while white matter forms the outer layer.
- Head, lung, secretory gland etc. are maintained and controlled by the autonomic nervous system.

## Exercise

**Short Answer Questions**

1. Describe the importance of hormone.
2. Mention the function of auxin and gibberellin.
3. Explain reflex action.
4. Describe the function of kidney.

**Multiple Choice Questions**

1. Which one of the following helps flowering (blooming)?
  - a. Gibberellin
  - b. Cytokinine
  - c. Florigen
  - d. Auxin
2. Which organ of the human body plays the key role in eliminating nitrogenous waste products?
  - a. Kidney
  - b. Skin
  - c. Nose
  - d. Anus

**Read the following paragraph and answer questions no. 3 and 4**

Pruma planted a money plant in a tub near the window of her room. As the plant grows fast, the twigs and tendrils bend towards the window. She brought the vine inside the room but the same thing happened again.

3. Why does Pruma's money plant creep towards the window?
  - a. Air
  - b. Water vapour
  - c. Light
  - d. Heat
4. Enhances the growth of Pruma's money plant-
  - i. Gibberellin
  - ii. Auxin
  - iii. Ethylene

**Which one of the following is correct?**

- a. i
- b. i & iii
- c. ii & iii
- d. i, ii & iii

**Creative Questions**

1.

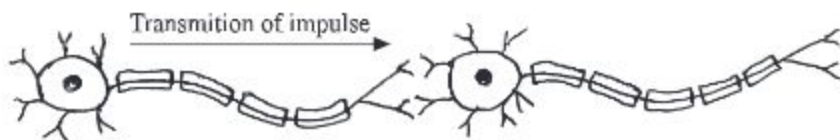

- a. What is hormone?
  - b. Explain the role of auxin in plants.
  - c. Explain the position of the above cell in cerebrum.
  - d. What are the importance of the above cell in transmitting impulses in human body? Explain.
2. Apu was drawing the picture of the unit of nervous system, attentively. At that time his sister Kanta poked him with her elbow from behind. Apu caught hold of Kanta's hand without seeing her. Then Apu told Kanta there is a relationship between his drawing and the catching of her hand.
    - a. What is the main excretory organ of human body?
    - b. What do you mean by tropic movement.
    - c. Describe the structure that Apu was drawing.
    - d. How is the ability of catching Kanta's hand related to the nervous process of Apu's body? Explain.

**Do yourself**

1. Why do you close your eyes when a light falls upon them? Explain with reasons.
2. Cut a twig of a patabahar plant. Observe it for a few days. Explain what happened and why it happened so?



## Chapter Six

# The Structure of Atoms

Everything that you see around you is made of tiny particles called atoms. Atoms are far too small to be seen, yet the Scientists have developed ideas about the structure of atoms indirectly through various experiments and observations. Different particles have different characteristics because they are built by different type of atoms which have different number of electrons, protons and neutrons.

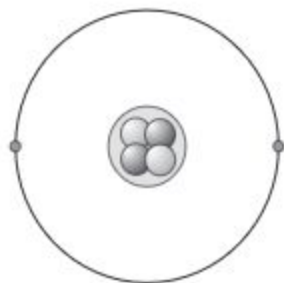

**At the end of this chapter we will be able to –**

- explain the structure of the atom;
- explain the atomic number and mass number;
- explain what is isotope;
- explain the distribution of electrons in atoms;
- explain how ions are formed;
- distinguish between cation and anion;
- formulate the chemical formula by using anion and cation;
- describe the use of isotope;
- appreciate the importance of isotopes in our life.

### **Lesson1-3 : The evolution of the idea of atoms and their structure**

By now you have known that all materials are formed by tiny particles. These particles can stay in two forms-one is called atom which is the smallest particle and the other is molecule, where more than one atom form a stable structure. About the tiny particles different scientists and philosophers have expressed different opinions at different time. The Greek philosopher Democritus put forward for the first time in 400BC, the idea that all matters are formed of tiny particles. According to him these particles are indivisible, which cannot be divided further. He called it atom. The word atom was chosen from the Greek word atomos which means indivisible. Two of his contemporary philosophers Plato and Aristotle

expressed different opinions. According to Aristotle, matter is continuous and as such particles of matter can be divided into smaller and smaller parts with work limit. Based on experimental evidence, in 1803 the English scientists John Dalton said that the smallest particle of an element is an atom which cannot be divided any further. Dalton's idea got acceptance and the idea of Aristotle was rejected. In fact atoms are not indivisible and are not the smallest particles of matter. Atoms can be divided. Atoms consist of smaller particles which are electrons, protons and neutrons.

To remove the limitations of the atomic concepts of Dalton, later others proposed alternate models of atom. Out of these models the most accepted atomic model is the model proposed by Rutherford and Bohr.

Rutherford and his co-workers at one stage carried out an important experiment to find out the correct structure of the atom. From the results of the experiment, Rutherford arrived at the conclusion that the whole of the positive charge and mass is confined to a small area at the center of the atom. This is now called the nucleus. He also explained that most of the space in an atom is empty and the negative charge is carried by the electrons, which have negligible mass and revolves around the central positive charge. Rutherford- model is similar to the model of the solar system but he did not say anything definitely about the orbit of the electron. Niels Bohr (in 1913) put forward the idea that the negative charge carrying particles revolve in certain allowed orbits.

From the above discussions, we can say that atoms are not indivisible. Atoms are formed by electrons, protons and the neutrons. At the centre of the atom there exists the nucleus. In the nucleus there are protons with positive charges and neutrons which are without charge. Most of the mass of the atom is concentrated at the nucleus. The space between the electrons and the nucleus is empty. In fact most of the space in the atom is void.

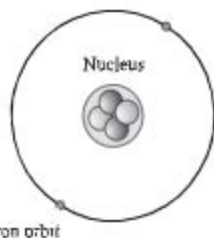

Fig. 6.1: Electron, Proton and Neutron in Helium Atom.



## Lesson 4-6 : Atomic number, mass number and isotopes

Different elements have different types of atoms. For example, the atom of hydrogen is different from the atom of oxygen. The atom of one element is different from the atom of another element in respect of atomic size, atomic mass and characteristics. Why is this difference? The difference in behavior of atoms arises from the difference in the number of protons and electrons. We know in a normal atom the net charge is zero. Therefore, the number of electrons and the number of protons are the same. To explain the behaviour of an atom, the number of protons is usually used. The number of protons in the nucleus of an atom of an element is its atomic number. There is only one proton in the hydrogen atom, therefore the atomic number is 1. There are 8 protons in an oxygen atom and its atomic number is 8. What information can you get from the atomic number?

Carbon has atomic number 6. Since the atomic number indicates the number of protons in the atom of a particular element and the number of protons is equal to the number of electrons in each atom, we can understand that Carbon atom must have 6 electrons.

Is it possible to know how many neutrons are there in an atom from its atomic number? No, it is not possible to know the number of neutrons in an atom from its atomic number. To know the number of neutrons in an atom one has to know the atomic number and the mass number of the atom.

The mass of the electrons in an atom is negligible. Most of the mass of an atom is due to the mass of the nucleus. Again the mass of a proton is nearly equal to the mass of a neutron. The mass number of an atom of an element is expressed as the total number of protons and neutrons in the atom. Thus the mass number of an element is equal to the number of protons in an atom of the element plus the number of neutrons in the atom.

For example, there are 8 protons and 8 neutrons in nucleus of an oxygen atom, therefore, the mass number of oxygen is 16. In the case of Sodium there are eleven protons and 12 neutrons. So the mass number of Sodium is  $11 + 12 = 23$ . It has been discussed before that, if the atomic number and the mass number are known, the number of neutrons in the atom can be found out. You will see it clearly from the following example.

**Example:** For an element A the atomic number is 17 and the mass number is 5. Find the number of protons and the number of neutrons in an atom of the element?



**Solution:** The atomic number of element A is 17. Since the atomic number is equal to the number of protons the number of protons in the atom of the element is 17. Again the number of electrons in an atom is equal to the number of the protons. So the number of electrons is 17.

In an atom the number of protons + the numbers of neutrons = mass number of an atom.

Therefore the number of neutrons in an atom of the element A = Mass number of the element A - the number of protons in the atom of element A

Thus the number of neutron of an atom of element A =  $35 - 17 = 18$

**Isotope:** Already you have come to know that the atom of an element have definite number of proton and electron but an element may have different mass number. This is because the atoms of an element may have different number of neutrons.

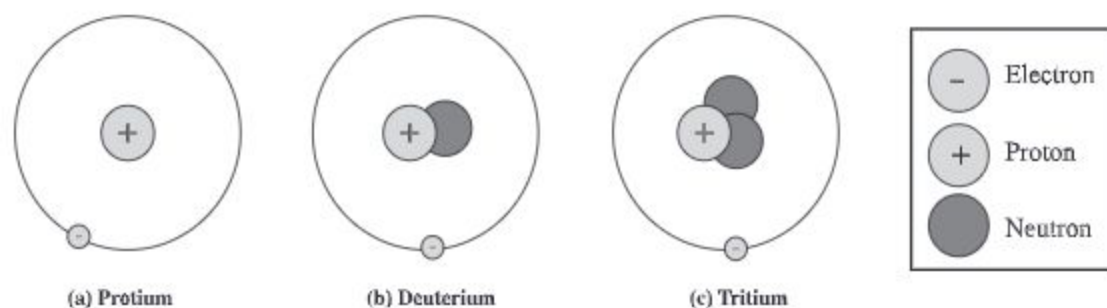

Figure 6.2: Hydrogen isotope

For example, every hydrogen atom has one electron and one proton. Most of hydrogen atoms (protium) have no neutrons. But some hydrogen atoms have one neutron. These atoms have mass number 2. Again some hydrogen atoms have two neutrons and its mass number 3. These isotopes are shown in the fig. 6.2. In the same way the different atoms of an element which have the same number of protons and electrons but different mass number are called isotopes of that element. Most of the carbon atoms have 6 protons and 6 neutrons in their nuclei. But some atoms have 7 or 8 neutrons in their nuclei. Thus mainly carbon has three isotopes.

## Lesson 7 and 8 : The properties and application of isotopes

Since the number of protons and electrons in different isotopes of an element are the same, there is no difference in their electrical and chemical properties. This is because it is the distribution of electrons in the atom that are responsible for all the electrical and chemical properties. But the isotopes can be separated due to the difference in their masses.

Usually a particular isotope of an element is more abundant because this isotope is more stable compared to other isotopes. The unstable isotopes radiate different radiations and particles due to radioactive decay. These are called radioactive isotopes. The properties of radioactive isotopes are used in different fields. Some of the uses of radioactive isotopes are described below:

**Medical uses of isotopes:** Isotopes are used in the diagnosis and treatment of diseases. If there is any defect in a narrow artery, it can be detected by sending radioactive isotope through the blood flowing in the artery. In the same way the affected cell of a cancer patient can be determined by sending radioactive isotopes. Again radioactive isotope can be used to destroy the cancer affected cells. Another use of radioactive materials is to use its radiation to sterilize medical instruments.

**Application in agriculture:** In agriculture the radiation from isotopes are used to control insects. Also it can be used to find out what type of fertilizer and what amount of fertilizer is needed for a specific crop.



Fig. 6.3: The use of isotopes in agriculture

**Food preservation:** Germs and bacteria can be killed by the radiation from radioactive isotopes. Therefore radioactive isotopes can be used to make food and fruits free from germs.

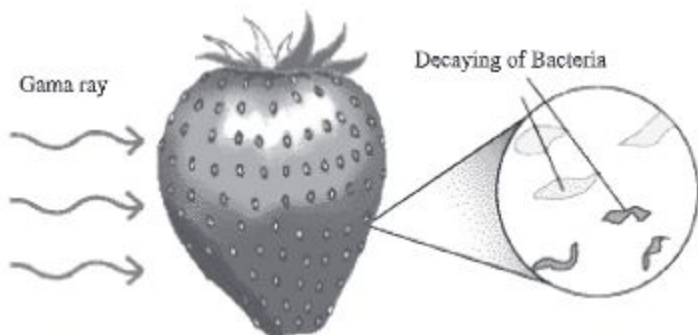

Fig. 6.4: Use of rays from radioactive materials for bacteria free food.

**Use of Isotopes in geological research:** You often have heard the news that fossils have been discovered which are many million years old. How do the scientists come to know the age of the fossils? It can be found out from the decay of the isotopes. From the ratio of the stable and unstable isotopes, it is possible to find out how old the fossil is.

### Lesson 9-11 : The way the electrons are distributed in an atom

You have known that electrons revolve around the nucleus. The electron has definite orbits. Now the question is how many electrons will stay in an orbit? Look at the diagram 6.2 which represents a hydrogen atom. In the hydrogen atom there is one electron in its orbit. In helium atom (Fig. 6.1) two electrons revolve around the nucleus in a single orbit. The rule by which the maximum numbers of electrons are distributed in the orbits is given by  $2n^2$  (here  $n = 1, 2, 3$  are the successive numbers of orbits). This is the rule for the allowed orbits. Some of these orbits can be filled and the rest can be empty. According to this a lithium atom has three electrons. Of these two electrons are in the first orbit and the third is in the second orbit. In the same way a carbon has six electrons, of which two are in the first orbit and the remaining four electrons are in the second orbit. According to the rule, the maximum number of allowed electrons in the first orbit is two, in the second orbit the number is eight. And in the third orbit the number is eighteen. These orbits are called energy levels, because each orbit corresponds to definite energy for the electron in it. Although the orbit is a path and energy level is a fixed value of energy, in general sense, these two terms refer to the orbit itself.

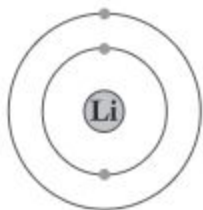

Fig. 6.5: Lithium atom

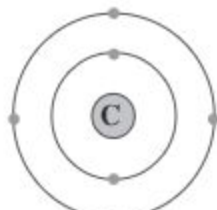

Fig. 6.6: Carbon atom



Now electron distribution of Sodium atom may be seen. There are eleven electrons in a sodium atom. How these electrons are distributed in different orbits? They must be in the order 2, 8, 1. This means in the first orbit there will be 2 electrons, in the second orbit there will be 8 electrons and in the third orbit there will be 1 electron.

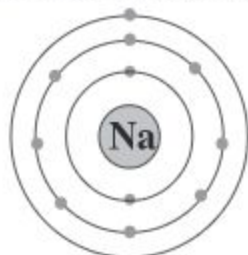

Fig. 6.7: Sodium atom

In the above diagram we have shown the distribution of electrons which is easy to visualize. But to write down the distribution of electrons in a sodium atom, we can express it as 2, 8, 1. We have shown below the distribution of electrons in the first 18 elements. Starting from the lowest atomic number

Element	Atomic Number	Symbol	Electronic configuration
Hydrogen	1		
Helium	2		
Lithium	3	Li	2, 1
Beryllium	4		
Boron	5		
Carbon	6		
Nitrogen	7	N	2, 5
Oxygen	8		
Fluorine	9		
Neon	10		
Sodium	11	Na	2, 8, 1
Magnesium	12		
Aluminium	13		
Silicon	14		
Phosphorus	15		
Sulphur	16		
Chlorine	17	Cl	2, 8, 7
Argon	18		

**Lesson 12-13: The electron distribution and properties of elements**

The properties of elements are basically determined by the electron distribution in their orbits. Generally atoms become active or inactive or charged due to difference in electron distribution.

If the last orbit has all the electrons that are allowed in that energy level, then that orbit is completely filled. This type of atoms is inert. For examples, there are two electrons in a helium atom. The first orbit is allowed to have two electrons. Therefore the helium atom is inert and stable. Every atom tends to go to such a stable state.

If the number of electrons in the last orbit or the highest state is such that it can complete it either by borrowing electrons or losing electrons, it will tend to do so. This is because, when the outermost orbit is complete, the negative charge of the electrons shield the equal number of protons in the nucleus. This reduces the energy of the system and the atom becomes more stable. This redistribution of the outer electron takes place by sharing the electron with the neighbouring atoms. For example consider the case of Sodium atom, it has 2 electrons in the first orbit, 8 electrons in the second orbit and 1 electron in the third orbit. Is it a maximum stable state? Surely not. If the sodium atom can lose the single electron in the third orbit, its outer most second orbit becomes full and the atom will become stable.

The sodium atom will easily lose one electron from the third orbit if some neighbouring atom has the tendency to grab an electron to fill its outermost orbit. But when the sodium atom lose one electron it is no longer charge neutral. Normal sodium atom is charge neutral, because it has the same number of protons in the nucleus as the number of electrons in the orbits. By losing one electron the sodium atom becomes positively charged. This charged atom is called an ion. If the charge is positive it is called cation. Thus sodium atom by losing an electron becomes anion.

Now let us take another example. Florin atom has electron distribution as 2,7. Is it a maximum stable state? Surely not. For stability it needs 8 electrons in the outermost orbit. It can either lose 7 electrons from the second orbit or can grabs one extra electron to complete the second orbit. From the energy consideration it is far more favourable to snatch one extra electron to complete the second orbit. In the vicinity of sodium atoms it can easily take one electron from the sodium atom. After receiving one electron from outside the florine atom becomes negatively charged. This makes it a negatively charged ion. It is called anion.

Thus by receiving or losing electron, atoms become ionized. Of the two atoms, the one which lose electron becomes cation. The atom which grabs electron becomes anion or negatively charged ion. As a result an attractive force works between these oppositely charged ions. If two oppositely charged ions come closer to each other, they form a bond. In this way atoms of elements form molecules of compounds. You will know more about in higher classes.



### What we have learned at the end of this chapter-

- Atoms are not indivisible. Atoms are formed by electrons, protons and neutrons.
- At the center of the atom there is the nucleus. In the nucleus there are positively charged protons and charge free neutrons. Most of the mass of an atom is in the nucleus.
- Negatively charged electron revolves in definite orbits or shells with the nucleus at the centre. The space between the electrons and the nucleus is empty. In fact most of the space in an atom is empty.
- The first orbit can have maximum of 2 electrons, the second orbit can have maximum 8 electrons and the highest number of electrons for the third orbit is 18. These orbits are also called energy levels.
- If the highest orbit has the number of electrons which is the maximum number allowed, then the orbit is completely full. Such atoms are inert.
- Atoms become comparatively stable and ionized by receiving or losing electrons.

## Exercise

### Fill in the blanks

1. According to the opinion of \_\_\_\_\_ atoms are indivisible.
2. Most of the mass of the atom is in the \_\_\_\_\_.
3. Most of the space of the atom is \_\_\_\_\_.
4. The number of \_\_\_\_\_ in an atom is called the atomic number.
5. The number of protons in the isotopes of an element is \_\_\_\_\_.



**Short Answers Question**

1. Describe and show with diagram the positions in an atom where electrons, protons and neutrons are located.
2. The atomic number of Nitrogen is 7. Show with diagram the distribution of electrons in a Nitrogen atom.
3. Discuss the application of isotopes in Medical treatments and Agriculture.
4. Explain with examples how cation and anions are formed.

**Multiple Choice Questions**

1. How many electrons can stay in the second orbit of an atom ?
  - a. 2
  - b. 8
  - c. 18
  - d. 32
2. It can be concluded from the experiment of Rutherford that—
  - i. atoms are indivisible.
  - ii. atoms can be divided.
  - iii. most of the space in an atom is empty.

**Which of the following is correct?**

- |            |             |
|------------|-------------|
| a. ii      | b. iii      |
| c. i & iii | d. ii & iii |

**After reading the sentence below, give answers to questions no. 3 and 4.**

In an atom of an element there are 10 proton and 8 neutrons .

3. What is the mass number of the atom?

a. 10	b. 16
c. 18	d. 26
4. Which element is this ?

a. Oxygen	b. Sulphur
c. Sodium	d. Neon

**Creative Questions**

1. The atomic number of atom X is 11. On the other hand the atomic number of atom Y is 17 and the number of neutron in the atom is 18.
- How many isotopes of Carbon are there?
  - What is meant by cation?
  - What is the mass number of atom Y?
  - Show the distribution of electrons in X and Y atoms and explain their ability to form bond between them ?

2.

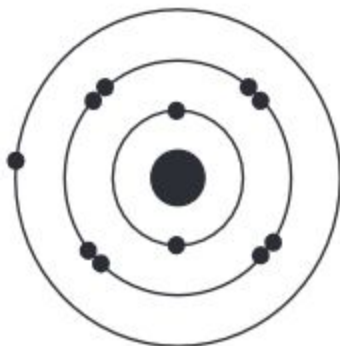

Fig-1



Fig-2

- What is meant by the word atom?
- What is meant, when it is said that the atomic number of oxygen is 8?
- Explain whether the Fig-1 of stimulus is active or inactive.
- Give a comparative description of the atomic structure of the number 1 and number 2 atoms.

# Chapter Seven

## The Earth and Gravitation

Newton put forward the law of gravitation that all particles in the universe attract each other by a force which is proportional to the product of their masses and inversely as the squares of their distance apart. Does this force of attraction vary from place to place? On what factor does this force depend? In this chapter, we will discuss gravitation, gravity, acceleration due to gravity, mass and weight.

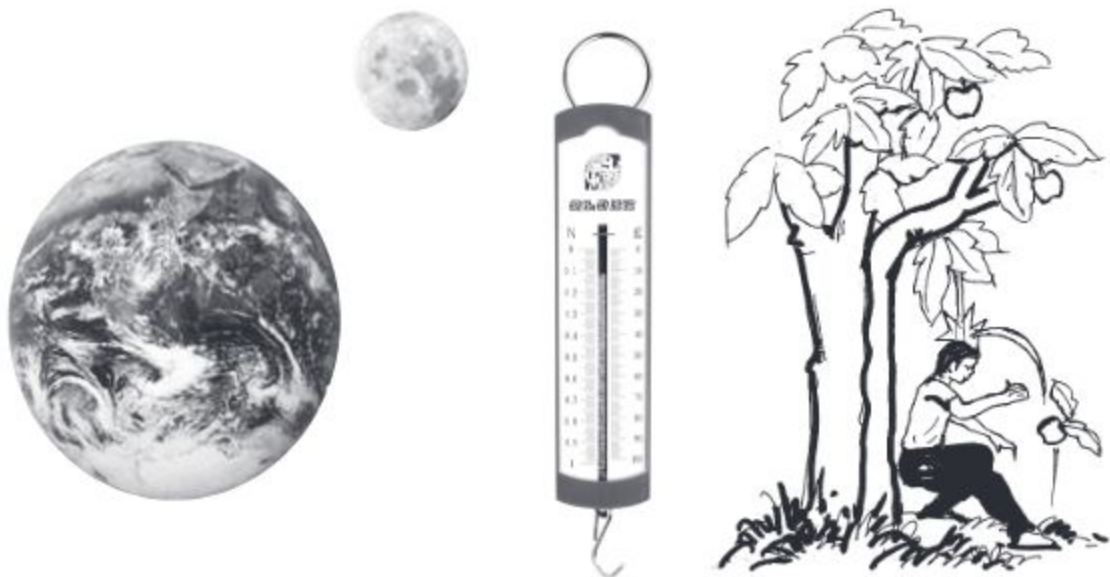

**At the end of this chapter we will be able to—**

- explain gravitation;
- explain the distinction between gravitation and gravity;
- explain the acceleration due to gravity;
- distinguish between mass and weight;
- explain the change of weight of an object due to the influence of gravitational acceleration;
- realize the impact of gravitational acceleration in our life.



**Lesson 1 : Gravitation**

If we jump we cannot go up very much. We fall back to the surface of the earth. Fruits fall from trees on the earth. Why do all these happen? The reason is that the earth attracts these objects towards it. It is not only the earth that attracts us, in fact all objects in the universe attract one other. This universal attractive force is called gravitation force.

You might have heard the story of Newton and the fall of an apple from the tree on the ground. As the story goes, Newton was sitting in his garden and was engaged in thought. Suddenly he saw an apple to fall on the ground. The question came to his mind, why did the apple fall towards the ground? Something must be attracting it towards the ground. After much speculation, he came to the conclusion that the earth attracts every object towards it. Later on, he came to more specific conclusion that it is not only the earth but all objects in the universe attract each other towards their centre. The attractive force that exists between any two particles in the universe is called gravitational force.

**Newton's law of gravitation and gravitational force**

Each particle in the universe attracts every other particle with a force which is proportional to the product of their masses and inversely proportional to the square of the distance between them. Newton developed an important theorem. That the gravitational attraction between two homogeneous spheres is proportional to the product of their masses and inversely proportional to the square of the distance between their centres. This is because for spherical bodies, the whole mass of the sphere can be assumed to be at the centre of the sphere, provided the observer is outside the sphere and the sphere is homogeneous.

If we assume that the two point objects or spherical bodies have masses  $m_1$  and  $m_2$  and the distance between them is  $d$ . Then the gravitational force  $F$  acting between them is given by

$$F = G \frac{m_1 m_2}{d^2}$$

Here  $G$  is the constant of proportionality. It is called the universal gravitational constant. This means that if two spherical bodies, each of which has mass one kilogram and the distance between them is one meter, the attractive force between them is  $G$  in magnitude. If the bodies are spherical the distance is measured from the centres of the spheres.

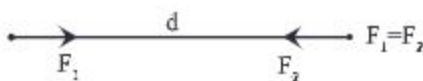

Fig. 7.1 : Gravitational force

From the formula of gravitation, we find that if the distance between the two object is fixed and the product of their masses is doubled, the gravitational force becomes double. When the product of the masses is three times, the corresponding force will be three times greater. If the distance between the objects is doubled, keeping the product of the masses constant, the corresponding force will be one fourth and when the distance is made three times larger, the corresponding force becomes one ninth of original force. The earth moves round the sun due to the influence of gravitational force just as a ball attached to a string can be made to revolve because of the tension in the string. Now answer— why do the planets revolve round the sun?

### Lesson 2-3 : Gravity and the acceleration due to gravity

**Gravity:** We know that every material or particle in the universe attracts each other. When this mutual attraction involves any two objects in the universe, we call it gravitation. If one of the objects is the earth and the attraction on the object is due to the earth, we call it gravity. When a cricket ball is thrown upwards, it falls back to the earth due to the attraction of the earth.

Just as the earth attracts the cricket ball towards it with a downward force, the cricket ball attracts the earth with the same upward force. But since the earth is very heavy compared to the cricket ball, it moves very little towards the cricket ball. On the other hand, the cricket ball having little mass compared to the earth, accelerates toward the earth. The accelerating force due to the earth on any object near to it is called gravity. Thus the attractive force between sun and the moon is called gravitation. But the attractive force that acts between you and the earth or between your science book and the earth will be called gravity.

**Acceleration due to gravity:** We know that when a force is applied on an object its velocity increases. The rate at which velocity increases with time is called acceleration. The force of gravity also causes acceleration. This acceleration is called the acceleration due to gravity. The acceleration due to gravity is indicated by  $g$ . Since  $g$  is a form of acceleration, its unit is that of acceleration, that is meter/second<sup>2</sup>.



Let us assume that  $M$  = the mass of the earth,  $m$  = the mass of an object near the earth,  $d$  = the distance between the object and the centre of the earth. From the formula of gravitation, the gravitation force,  $F = G \frac{Mm}{d^2}$ .

Again we get from the relation between force and acceleration, the force of gravity = mass  $\times$  acceleration due to gravity. That is  $F = mg$ .

From the above relation we get,

$$mg = \frac{GMm}{d^2}$$

$$\text{or, } g = \frac{GM}{d^2}$$

In this equation  $m$  is absent on the right side. This means that the acceleration due to gravity does not depend on the mass of the body subjected to gravity. Since  $G$  and the mass of earth  $M$  is constant, so the value of  $g$  depends on the distance of matter  $d$  from the centre of earth. Thus the value of  $g$  is independent of the mass of the object but is not independent of its position. It means that if the distance of different places  $d$  is different from the center of the earth, the value of  $g$  will also be different at different places.

**Variation of the acceleration due to gravity:** The distance of the surface from the center of the earth, that means if the earth is considered round, its radius will be  $= R$ , then  $g = \frac{GM}{R^2}$ .

Since the earth is not a perfect sphere,  $R$  is not really constant. So the value of  $g$  is not equal everywhere at the surface of the earth. As we move from the pole to the equator, the value of  $R$  increases and the value of  $g$  decreases. At the equator the value of  $g$  is minimum. It is 9.78 meter/sec<sup>2</sup>. The value of  $g$  in the polar region is 9.832 meter/sec<sup>2</sup> at the surface of the earth. For the convenience of calculation the value of  $g$  is taken as 9.8 meter/sec<sup>2</sup>. At the surface of the earth, the value of  $g$  is 9.8 meter/sec<sup>2</sup>. It means for a freely falling body near the surface of the earth, the velocity increases by 9.8 meter/sec at every second.

If a body is allowed to fall from above, it reaches to the surface of the earth due to the force of gravity. If we allow a piece of stone and a piece of paper to fall from the same height, will they reach the surface of the earth at the same time? Since the acceleration due to gravity does not depend on the mass of the body, therefore the acceleration acting on both the stone and the paper are the same. As a result both of them should be expected to reach the surface of the earth at the same time. But in reality the stone will reach the surface of the earth before the paper. This is because of the air resistance. Air obstruction is relatively high on a piece of paper. So, it falls slowly downwards. The stone and the piece of paper would have reached the ground at the same time if there were no wind obstruction.



**Lesson 4: Mass and weight**

In our day to day use of language we often make no distinction between mass and weight. But in physics the two words mean different entities. In fact when we say that the weight of a bag of rice is 50 kg, we actually refer to their masses. In this respect the use of the word weight of an object is scientifically wrong. But what is the difference between mass and weight?

**Mass:** All objects are made of materials. Mass of an object refer to the amount of material present in an object. This property of the material does not depend on location, shape or state of motion, according to Newtonian physics. The mass of the objects depends on the number and kind of atoms and the bonds by which the object is formed. The international unit of mass is kg. A heavy mass is expressed in units of tones. One ton is 1000 kg. Small masses are expressed in units of gram. Thus the mass of your pencil is 5 gram. Thousand gram make one kilogram(kg). More appropriate meaning of mass comes from Newton's law  $F = ma$ .

Thus the mass of an object is the ratio of  $F$  and acceleration. If the mass is greater it resists the increase of velocity more for the same applied force. Mass is thus related to inertia of motion.

**Weight:** We know that if a body is thrown upward, it comes back to the earth. This is due to the weight of the body which push the object towards the earth. We can say the force of gravity causes this downwards pull.

The force with which the earth attracts an object is called its weight. If only the force of gravity acts on an object and the gravitational acceleration is  $g$  at some point on earth and the mass of the object is  $m$  then the weight of the object at that point will be  $W$ ,  $W = mg$ .

The unit of weight is newton. The weight of an object with mass 10 kilogram is,  $W = 10 \times 9.8 \text{ newton} = 98 \text{ newton}$ .

Generally, we can determine the weight of an object by using a spring balance.

**Lesson 5 : The relation between mass and weight**

We know that the amount of material in an object is its mass. It is a constant parameter, which does not change due to change of its location to any height above the earth. If an astronaut has a mass 75 kg, it will remain unchanged when he is in the surface of the earth or on the surface of the moon or in an orbit of the moon or earth. The amount of material by which an astronaut is built does not change due to change of position and that is why its mass remain unchanged. Since the mass of an object is constant, its weight changes due to change in the

value of  $g$ . As one goes more and more above the surface of the earth, the weight of an object becomes less and less. The reason for which the value of the acceleration due to gravity changes are also the causes of change in weight of an object. The weight of an object is not an fundamental parameter. For example, an object may have weight at one place and may not have any weight at another place. At the centre of the earth, the value of acceleration due to gravity is zero and therefore, the weight of an object there must also be zero. At a distant space, where there is no gravitational force, the weight of an object must be zero.

The value of the gravitational acceleration of the moon is about  $\frac{1}{6}$  of the gravitational acceleration on the earth. So, the weight of a 1kg object will be about  $\frac{9.8}{6}$  newton (N) = 1.63 N.

The weight of an object at a location depends on its distance from the centre of the earth. If the distance is increased, the force of gravity due to earth at that point decreases. As a result, the weight of an object there decreases. At the surface of the earth the weight of mass 1 kilogram is 9.8 newton. But at a distant point from the earth, its weight decreases with the increase of distance.

The weight of an object vary slightly also at different positions on the surface of the earth. One reason for this is that, the earth is not a perfect sphere and the acceleration due to gravity is not same at all the points on the earth's surface. However, this variation is so small that it can be detected only by using a very sensitive weighing machine. We neglect this variation in most of our calculation. An object will weigh maximum at the two poles. At these places one kilogram will weigh 9.83 newton. At the equator, this weight will be least with a value of 9.78 newton. At the equinoctial point, the weight is 9.79 newton.

The weight of a body increases in proportion to its mass. Therefore, the instruments which are used to determine weight can also be used to measure the mass of the object. Often spring balance is calibrated in units of kilogram. Balances and weighing instruments are calibrated in such a way that we sometimes use the kg unit for measuring both mass and weight. It is of course a wrong practice. Weight is a form of force and for scientific calculation it should be expressed in units of newton. When we buy a packet of rice or milk on which one kg is marked, we understand that each of these packets has one kilogram mass. But their weights are not 1 kg. On the surface of the earth they will weigh 9.8 newton. These packets will weigh different from planets to planets or on the moon, although their masses will remain unchanged.



**Lesson 6: The acceleration due to gravity and the weight of an object are different at different places on the earth**

The weight of an object depends on the acceleration due to gravity  $g$ . The reasons for which the value of  $g$  changes are also the reasons for which the weight of an object changes. The weight of an object is not an invariant quantity. Its value changes from place to place on earth. The reasons, for which the weight of an object changes are described below –

**(A) At different places on the surface of the earth:** The weight of an object is different at different locations on the earth because of the shape of the earth and its different locations.

**(1) For the shape of the earth:** Since the earth is not a perfect sphere, all points on the surface of the earth are not at equal distance from the centre of the earth. As the value of  $g$  at a point depends on its distance from the centre of the earth, the value of  $g$  becomes different in different places on the earth's surface. At the equatorial area the radius of the earth is largest and the value of  $g$  is lowest (9.78 meter/sec<sup>2</sup>) there. This is why weight of an object is minimum in this region. As we move from the equator to the poles, the radius of the earth decreases and the value of  $g$  increases (9.83 meter/sec<sup>2</sup>). Because of this the weight of an object also increases. At the poles the radius of the pole is minimum and the value of  $g$  is maximum. As a result, the weight of an object is highest in this region.

**(2) For the diurnal rotation of the earth:** Gravitational acceleration decreases for rotational motion or instantaneous motion of earth around its own axis. If there was no instantaneous motion (i.e. assume there is no day and night on earth), then the value of gravitational acceleration would have been greater than the current (rotating earth) gravitational acceleration.

**(3) For angular distance (latitude) from pole:** Gravitational acceleration increases progressively from equatorial region to polar region. This also increases the weight of the object.

**(B) For the increase of height from the earth's surface:** As we soar to higher heights, the value of the acceleration due to gravity decreases. Because of the greater height from the surface of the earth, the lower is the value of the weight of an object. Thus the value of  $g$  is less at the top of a mountain.

**(c) At a point inside the earth:** As we go deeper inside the earth the value of the acceleration due to gravity goes on decreasing. Because of this the weight of an object goes on decreasing, as we go deeper and deeper inside the earth. Thus the weight of an object is less inside a mine. At the centre of the earth the value of the acceleration due to gravity is zero. Therefore, if we take an object to the centre of the earth, there will be no force of attraction of the earth on the object and its weight will be zero.



## Lesson 7 - 8 : The variation of weight in a lift and in space: Weightlessness

The value of  $g$  is constant at any given location on Earth. As a result, a person's weight is also constant at that location. However, a person can experience fluctuations in the perceived weight, and in certain situations, may even feel weightless. This difference arises because actual weight and perceived weight are not the same. An example of this is the perceived weight inside the elevator.

**(1) Perceived weight inside a motionless lift:** A rider inside a stationary elevator exerts a force on the floor equal to the actual weight ( $w = mg$ ). The elevator floor, in turn, exerts an equal and opposite reaction force on the rider, which the rider perceives as his weight. In this situation, the perceived weight is equal to the actual weight.

**(2) Perceived weight in an elevator moving at constant velocity:** A rider in an elevator moving up or down at constant velocity is also moving at the same constant velocity. As a result, only the rider's actual weight (the force of gravity) acts on him. The rider exerts a force on the elevator floor equal to his actual weight, and the elevator floor exerts an equal and opposite reaction force on the rider. Therefore, the rider's perceived weight is equal to his actual weight.



Fig. 7.2 : Lift

**(3) Weight in an upward-accelerating elevator:** To start an elevator moving upward from a stationary position, an additional upward force—greater than the combined weight of the elevator and the rider—must be exerted by the elevator's cable. This causes the floor of the elevator to exert a force on the rider that is greater than his actual weight, resulting in a perceived weight that is higher than his actual weight. This perceived weight can also be considered a reaction force.

**(4) Weight in a downward-accelerating elevator:** To move a stationary elevator upward, the tension in the elevator cables must be reduced from the total weight of the elevator and the rider. When the elevator moves downward, the floor of the elevator exerts a force on the rider that is less than their actual weight. So, the rider's perceived weight is less than his actual weight.

**(5) Weight inside a free-falling elevator:** If the lift's supporting cable or wire breaks, the elevator will fall freely downward with the rider, ignoring air resistance and other friction. Since there is no tension in the elevator's cables due to the break, the floor of the elevator exerts no force on the rider. As a result, the rider experiences weightlessness.

The free fall of an elevator is similar to a spacecraft orbiting the Earth or the Moon. Astronauts orbit the Earth in a circular path at a fixed altitude. The weight of the spacecraft ( $W = mg$ ) and the weight of the astronaut ( $W = mg$ ) contribute to this circular motion, and both the spacecraft and the astronaut experience the same acceleration. Therefore, the acceleration of the astronaut relative to the walls of the spacecraft is zero, and the astronaut does not exert any force on the walls or floor of the spacecraft. As a result, the astronaut does not feel any reaction force against his weight and experiences weightlessness. In this condition, if an object is released from the spacecraft, it will not fall; even if a glass of water is turned upside down, the water will not fall either. Everything will appear weightless. However, nothing is truly weightless; the astronaut still has mass, the location has gravitational acceleration ( $g$ ), and thus, there is still the Earth's attraction, or weight. This momentary sensation of weightlessness is created simply because the spacecraft is moving with acceleration equal to  $g$ . If, at that moment, the spacecraft is not orbiting the Earth in a circular path or is standing still rather than free-falling toward the Earth, the astronaut will feel his weight.

**New words:** Gravity, gravitational constant, acceleration due to gravity, mass, weight, weightlessness, lift.

**What we have learned at the end of this chapter**

- The attractive force that exists between any two material particles in the universe due to their masses is called the gravitational force.
- Every material particle in the universe attract every other particle and the value of the mutual attractive force is proportional to the product of their masses and inversely proportional to the square of the distance between them. This force is directed along the line joining the two masses
- The attractive force that works between the earth and any other material is called force of gravity.
- The rate at which the velocity of a free falling body change due to the force of gravity is called the acceleration due to gravity.
- The ideal value of the  $g$ , acceleration due to gravity is  $9.8 \text{ meter/sec}^2$ .
- The amount of material present in an object is its mass.
- The force with which the earth attracts an object to its centre is called the weight of an object.

## Exercise

### Short Answer Questions

1. If the distance between two objects is increased three times, how much change will occur to the force of attraction between them and why this change will occur?
2. What do you understand by the acceleration due to gravity?
3. Write down three points of difference between mass and weight.
4. Explain why the masses of two objects will be the same when measured by a balance on the earth and the moon.
5. Why there is a difference in the weight of the same object when measured at the polar region and in the equitorial region.

### Multiple Choice Questions

1. What is the unit of weight?
  - a. gram
  - b. kilogram
  - c. quintal
  - d. newton
2. Which of the following comments is correct with reference to the mass of an object?
  - a. The mass of an object changes with the change in its location.
  - b. The attractive force on an object due to the earth is nothing but mass .
  - c. The net amount of material in an object is its mass.
  - d. The unit of mass is newton.



From the figure given below, give answer to questions no. 3 and 4

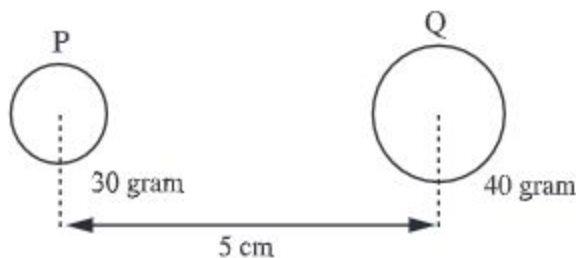

3. The attractive force between P and Q depends on—
- the masses of the object.
  - the distance between the objects.
  - the nature of the medium.

**Which one is correct?**

- |             |                 |
|-------------|-----------------|
| a. i & ii   | b. i & iii      |
| c. ii & iii | d. i, ii & iii. |
4. If the product of the masses of the two objects becomes  $3600 \text{ gram}^2$ , what will be the change in the force of attraction between them?
- |                        |                       |
|------------------------|-----------------------|
| a. Will be half        | b. Will be double     |
| c. Will be three times | d. Will be four times |

### Creative Questions

- Nuha let a stone of mass 50 gram and a piece of paper to fall from the fifth floor of their building at the same time. Her brother standing on the ground observes that stone reached the ground earlier than the piece of paper.
  - What is gravity?
  - What is meant by acceleration due to gravity?
  - Find the weight of the stone?
  - Explain why the stone reached the ground earlier than the paper.
- A body of mass 120 kg is carried to the moon by a rocket. It is observed that, though the mass of the object did not change, its weight changed.
  - What is mass?
  - What is the difference between mass and weight?
  - Find the weight of the object on the moon.
  - Will there be any change of weight of the object on the moon? Explain.



# Chapter Eight

## Chemical Reaction

Different types of chemical reaction are going on around us. There chemical reactions are some times releasing energy, sometimes creating useful new materials and sometimes helping us cure diseases.



**At the end of this chapter we will be able to—**

- explain different types of chemical reactions ;
- explain different types of energy transformations through chemical reactions;
- explain the transformations of energy in dry cells;
- explain electrolysis;
- use properly the chemicals and different instruments in chemical experiments.
- appreciate the contributions of chemical reactions in our life;

### **Lesson 1-2 : Symbol, formula and valency**

In class seven, you have got some ideas about symbol and formula. According to structure, chemists have divided all the substances of the world as elements and compounds. Till now, 118 elements have been found out. Generally, symbols are expressed by the first one or two letters of the English or Latin name of the elements. The short expression of the element is called symbol. For example :

Hydrogen H, Oxygen O, Calcium Ca etc.

Again, the short expression of molecule of compound is called formula. For example : formula of hydrogen molecule  $H_2$ , Oxygen molecule  $O_2$ , Hydrogen chloride molecule HCl etc.

To write the formula of compound, we need to know the valency of the element. According to the number of valency of the element, elements form compounds by chemical bondage. We can compare the valency of elements with our hand. The elements having valency one, means it has one hand. Hydrogen and chlorine both are one handed elements. So, their valency is one. Therefore, the formula of hydrogen chloride is HCl. The valency of oxygen is two. It means, the one atom of oxygen has two hands. Through these two hands, oxygen can be attached with two atoms of one handed hydrogen. For this reason, the formula of water is  $H_2O$ .

The valency of nitrogen and carbon are 3 and 4 respectively. So, the formula of ammonia is  $NH_3$  and methane is  $CH_4$ . The formula of hydrogen chloride, water, ammonia and methane can be shown in the following :



It may be mentioned here that some elements have more than example : the valency of sulphur is 2 and 4, Iron is 2 and 3 etc.

Therefore, the valency of the element means the number of hydrogen atom attached to that element. At the time of formation of a compound, it is to be considered that all the hands or valency of an element are satisfied.

**Table : The valency of some elements and radicals**

Element	Valency-1	Valency-2	Valency-3	Valency-4
Non-metal	Hydrogen (H) Fluorine (F) Chlorine (Cl) Bromine (Br) Iodine (I)	Oxygen (O) Sulphur (S) Carbon (C)	Nitrogen (N) Phosphorus (P)	Carbon (C) Sulphur (S)
Metal	Sodium (Na) Potassium (K) Copper (Cu) (ous) Silver (Ag) Gold (Au) (ous)	Calcium (Ca) Magnesium (Mg) Zinc (Zn) Iron (Fe) (ous) Copper (Cu) (ic) Tin (Sn) (ous) Lead (Pb) (ous)	Aluminium (Al) Iron (Fe) (ic) Gold (Au) (ic)	Tin (Sn) (ic) Lead (Pb) (ic)
Radicals	Ammonium ( $NH_4^+$ ) Hydroxyl ( $OH^-$ ) Nitrite ( $NO_2^-$ ) Nitrate ( $NO_3^-$ ) Bicarbonate ( $HCO_3^-$ )	Carbonate ( $CO_3^{2-}$ ) Sulphate ( $SO_4^{2-}$ ) Sulphite ( $SO_3^{2-}$ )	Phosphate ( $PO_4^{3-}$ )	

In the above table  $\text{SO}_4^{2-}$ ,  $\text{CO}_3^{2-}$ ,  $\text{NO}_3^-$ ,  $\text{NH}_4^+$  etc. group of atoms do not stay independently. They participate in compound formation like elemental atom. This group of atoms is called radical.

To write the molecular formula, the following rules are to be mentioned.

1. If the valency of the element or radical is same, it is not necessary to write valency in the formula. Only element and radical are to be written together. For example: CaO (calcium oxide),  $\text{NH}_4\text{Cl}$  (ammonium chloride),  $\text{NH}_4\text{NO}_3$  (ammonium nitrate) etc.
2. If the valency of one element is any multiple of valency of another element, the valency of both elements is divided by that multiple. Then the divided result is exchanged and is written as suffix. For example: carbon dioxide  $\text{C}_2\text{O}_4 \rightarrow \text{CO}_2$ . Here the valency of carbon and oxygen is respectively 4 and 2.
3. If the valency of both elements is different but not any multiple like valency of A is X and the valency of B is Y then the formula of compound formed- with A and B is  $\text{A}_y\text{B}_x$ . The valency of element A is written at the suffix on B and the valency of element B is written at the suffix of A. For example aluminium oxide ( $\text{Al}_2\text{O}_3$ )

### Lesson 3-4 : Chemical equation

To describe the chemical reaction we need to know about chemical reaction. A chemical reaction can be divided into two parts.

One part contains the reactants and in the other part, the products or the newly formed substances. For example :

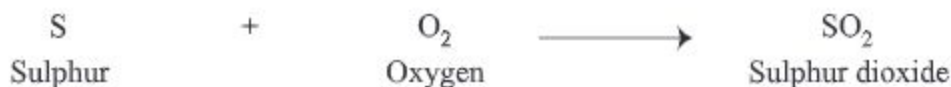

Reactants represent the prior state of the reaction and products the resultant state of the chemical reaction. In any chemical reaction, atoms cannot be created or destroyed; but they are rearranged only. The total number of atoms present in the reactants before the reaction always equals the total number of atoms of the product after the reaction. So the reactants and their product have the same number of atoms of a specific element. In the light of the above discussion, chemical equation may be defined as follows:

A chemical equation is a shortened expression of a chemical reaction. It uses some symbols, formulas and some mathematical signs to denote the reactants and the products. For example :





### The rules of writing chemical equations

1. In a chemical equation the formula or symbols of the reacting substances or reactants are written on the left of the sign of equality (=) and the symbols or formulas of the products are written on the right of it.
2. If the reactants or products are more than one, a plus (+) sign is put between the formula and the symbols.
3. If the number of molecule is more than one then the number is used before the formula.
4. An arrow sign ( $\longrightarrow$ ) is used to indicate that the reaction moves towards the products from the reactants. Instead of an arrow sign, an equals sign (=) may also be used. However, the equation has to be balanced on both sides.
5. The number of atoms of different elements present in the reactants before chemical reaction must be equal to the number of atoms of different elements in the products formed after the reaction. So, to make balance the symbol or formula must be multiplied by the required number.

### To balance the chemical equation

Hydrogen reacts with oxygen to produce water. So the formula of hydrogen and oxygen is to be written on the left of the equals sign (=) and the formula of the product will be written on the right. The reaction may be expressed as follows :



The number of H and O atoms before the reaction and their numbers after the reaction should be same. To make the number equal it will have to be multiplied on the right side by 2. The equation now stands as :



From the above equation the total number of oxygen and hydrogen atoms before and after of the reaction can be calculated :



Therefore, the number of atoms before and after the reaction is equal.

## Lesson 5 : Chemical reaction: addition

**Activity:** Understanding addition reaction

**Necessary components:** test tube, mortar, spirit lamp or burner, iron powder, sulphur, balance

**Methodology:** Properly clean the test tube and dry it. Using the balance measure 1 gram of iron powder and 4 gram of sulphur (keeping the ratio same different amounts of iron and sulphur can be taken) and grind them together in the mortar. Put the powders in the test tube. Now heat the bottom of the test tube using the flame low while heating. When the mixer in the test tube becomes red hot, stop heating, keep the test tube above the mortar so that in case the test tube breaks the materials in it will not be spoiled. After cooling the test tube, break it and separate out its contents.

The material that you obtain from the test tube will look deep gray. You will see that the light yellow sulphur or iron in it, became the iron powder and the sulphur chemically combined to produce a new material called ferrous sulphide.



This type of chemical reaction in which more than one element combined to produce a new kind of chemical substance is called synthesizing reaction. In the same way zinc and sulphur can chemically react to produce zinc sulphide.



It is to be mentioned here that in the above two reactions compounds are formed from elements. However, it is also possible that two compounds can chemically combine to form a new compound. For example, ammonium chloride is produced by adding hydrogen chloride with ammonia.



## Lesson 6-7 : Combustion reaction

**Activity:** Observation of combustion reaction between sulphur and oxygen.

**Necessary components:** A combustion spoon with a long handle, some amount of sulphur, spirit lamp or burner

**Methodology:** Take some sulphur in your combustion spoon. Go on heating the spoon with the flame of your burner. What do you find?

First you will see sulphur to melt and then you will see blue flame and smell a pungent smell. The heating of sulphur reacts with oxygen in the air and produces sulphur dioxide ( $\text{SO}_2$ ) gas which gives pungent smell.



**Activity:** Observation of combustion reaction between magnesium and oxygen.

**Necessary components:** Magnesium ribbon, forceps (eight centimeter). Spiritlamp or burner

**Methodology:** Wear protective spectacles. Hold the end of the ribbon on the flame you can do it by a lights also. Observe carefully, what happens?

The ribbon catches fire and a bright flame is seen. It happens because magnesium burns due to the reaction with the oxygen of the air and we see the flame. When all the magnesium is burnt out, the flame will extinguish automatically. Do you find anything like ashes? It is actually magnesium oxide which has been formed through the burning of magnesium in oxygen.



**Activity:** To know the process of burning of a candle.

**Necessary components:** Candle, match

**Methodology:** Ignite the candle using a match stick. Observe carefully what is happening? With the passage of time the size of the candle reduces. Due to burning the candle melts at the top by the heat produced. A small part of the melted wax flows down the candle, but most of the melted wax turns into vapour by being sucked up through the wick of the candle. This vapour, by combustion process, reacts with the oxygen in the air and produce heat and light.



## Lesson 8-9 : Substitution or displacement reaction

**Activity:** Observing the reaction between iron and copper sulphate.

**Necessary components:** Iron powder, copper sulphate, water and test tube

**The procedure:** Fill the test tube with water to one fourth its volume. Take some copper sulphate in it and shake to make a solution of copper sulphate. Now put in some iron powder in this blue solution of copper sulphate and shake thoroughly. Do you find any change? The blue colour of solution is gradually turning into green and small particles are forming at the bottom of the test tube. Why the blue colour of the solution turns green?

Here a chemical reaction has taken place, as a result ferrous sulphate and copper have been formed. The colour of iron sulphate is light green which turns the blue colour of the solution into light green.



In this reaction iron is removing copper from copper sulphate and occupying its place to form ferrous sulphate and pure copper.

This type of chemical reaction, where an element replaces another element from a compound and occupies its place producing a new compound is called displacement reaction.

You can add zinc, magnesium etc. and see what type of change occurs.

### Decomposition reaction

**Activity:** Observing the decomposition reaction of limestone.

**Necessary components:** Limestone, spatula or spoon, test tubes, lime water, outlet tube, bunsen burner or spirit lamp, clamp, stand, cork and hand gloves

**Methodology:** Wear the hand gloves and with the help of the spatula take 5 gram of limestone in the test tube. Now heat the bottom of the test tube with the flame of the burner. Observe very carefully.

Carbon dioxide is being produced. The limestone which was taken in the test tube decomposed into carbon dioxide gas and formed calcium oxide due to heating ..

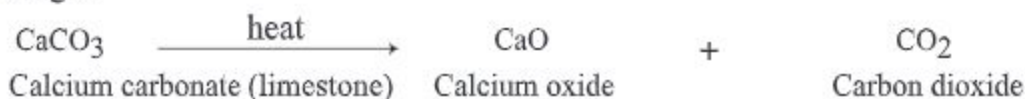

Now you can examine whether the gas is carbon dioxide or not. Take 1-2 milliliter of lime water in the other test tube and fix it as shown in the figure. You will see that the lime water is turning opaque. The carbon dioxide thus produced passed through the outlet tube to the second test tube and caused reaction there between lime water and carbon dioxide. The lime water becomes opaque due to the formation of calcium carbonate.



Examples of decomposition reactions are given below :

If copper carbonate is heated, it breaks and produces copper oxide and carbon dioxide.

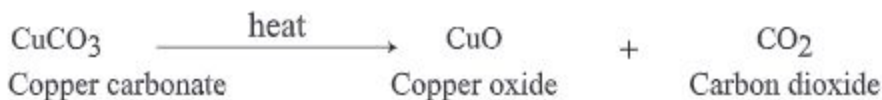

On the other hand when potassium chlorate is heated it decomposes into potassium chloride and oxygen gas.

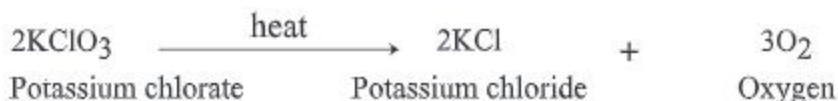

Fig. 8.1: Decomposition

### Lesson 10-11 : Transformation of energy through chemical reaction

**Your Activity:** You have known what type of chemical reaction goes on when a candle burns. Can you say now if any energy transformation occurs here? If you put your hand near the candle you feel hot. Again if the candle is ignited in the dark things become visible. We can therefore say that we feel hot because the burning candle produces heat and we can see things around the candle because it produces light. Candle is a chemical substance. When it is burned, the chemical energy stored in it transforms into heat energy and light energy. We use heat energy for cooking. Thus we find that chemical reaction cause transformation of energy.

**Activity:** The reaction between baking soda and lemon juice.

**Necessary components:** Baking soda, lemon juice, dropper

**Methodology:** Take some baking soda in a test tube. Gradually add lemon juice to it by using the dropper. What do you find? There will be lot of bubbles. If you touch the bottom of the test tube do you feel it cold?

Lot of citric acid is present in the lemon juice which reacts with the baking soda to produce sodium citrate, carbon dioxide gas and water. The bubbles you see are nothing but carbon dioxide gas.



Why is the test tube felt cold? The reason is that the reaction absorbed heat.



Now you can add vinegar to baking soda instead of lemon juice and see what happens?

**Activity:** Experiment for the reaction between lime water and vinegar.

**Necessary components:** lime, vinegar, beaker, hand gloves, dropper

**Methodology:** Using the hand gloves put some lime in the beaker. Now gradually add vinegar with the help of the dropper. Touch the beaker by your hand. Do you feel it hot? What is the reason? Here, due to the reaction between lime and vinegar. Calcium acetate and water is formed and lot of heat is released. Due to the generation of heat the beaker is felt hot.

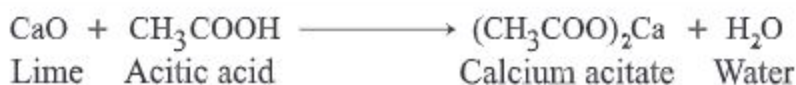

Here lime is alkaline substance and acetic acid is acidic substance. This type of reaction where substances of opposite characteristics react with each others and produce neutral substance is called neutralization reaction.

Now you can add lemon juice instead of vinegar and see what type of reaction occurs?

**Activity:** Observation of the reaction between lime water and vinegar.

**Necessary components:** Lime, water, vinegar, beaker, hand gloves, spatula, dropper

**Methodology:** Take five gram of lime ( different amount can also be taken). Add 40 gram of water drop by using the dropper. Touch the beaker with hand gloves on. Do you find any difference after adding water?

The beaker is getting very hot and the solution is bubbling as happens to boiling water. Here due to the addition of water into lime, there is a chemical reaction between them and calcium hydroxide is formed.



The product  $\text{Ca(OH)}_2$  is well known as slaked lime. Slaked lime or  $\text{Ca(OH)}_2$  dissolves in water very slightly. Huge heat-energy is produce in this reaction. As a result, water evaporates. The saturated solution of  $\text{Ca(OH)}_2$  in water is called lime water.

Keep the suspensions that you get from the above experiment for some time. The clean water that you get at the top is lime water.



## Lesson 12-14 : Dry cells

Dry cells are portable source of electrical energy. We use dry cells in torch light, remote controller, toy cars and in many electric machines. We will discuss how this cell is made and how it works.

To make such a dry cell first of all, ammonium chloride ( $\text{NH}_4\text{Cl}$ ), charcoal powder and manganese dioxide ( $\text{MnO}_2$ ) to be mixed thoroughly with little water added to make a paste. This mixture is taken in a cylindrical shaped zinc container. A carbon rod is introduced at the centre of the container in such a way that it does not touch the zinc container. At the top of the carbon rod there is a metal cup. The upper part of the cell is covered by a layer of pitch. The surface of the zinc cylinder acts as the negative electrode or as the anode. The carbon rod with the metal cap acts as the positive electrode or cathode.

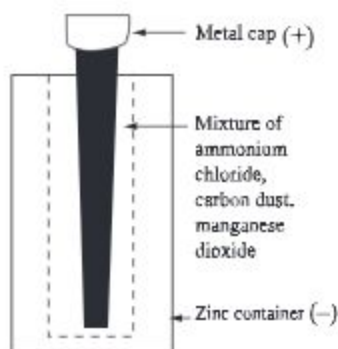

Fig. 8.2: Dry cell

Now let us see how it works-

**Activity:** To make a electric circuit using a dry cell and observe the energy transformation.

**Necessary components:** An electric bulb, dry cell, two copper wires

**Methodology:** Connect one end of a copper wire to the anode of the dry cell. Connect the other copper wire with the cathode of the dry cell. Now connect the free ends of the copper wires through the bulb as shown in the figure. The bulb will light up. This is because an electric circuit is completed through the cell, bulb and the wires.

What type of energy transformation did take place here? The completion of the electric circuit causes the bulb to give light. This light is coming from the battery. The source of energy of the cell is the chemicals used in the cell. This means zinc, charcoal powder, ammonium chloride and manganese dioxide. We can say the chemical energy stored in the chemicals in the cell is the source of electrical energy.

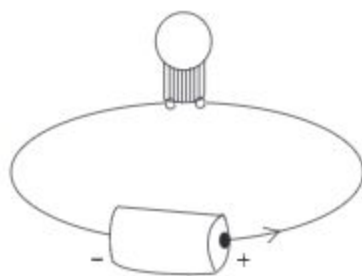

Fig. 8.3: Dry cell circuit

## Electrolysis

**Activity:** To know about electrolysis.

**Necessary components:** One dry cell, two copper wires, two zinc rods (electrode), water, salt, one glassware.

**Methodology:** Take 300 milliliter of water, 30 gram of sodium chloride in a glassware and stir them thoroughly. Now connect the two zinc rods to the battery using the copper wires as shown in the figure. Look carefully at the zinc rods. Do you find bubbles of gas on the body of both the rods?

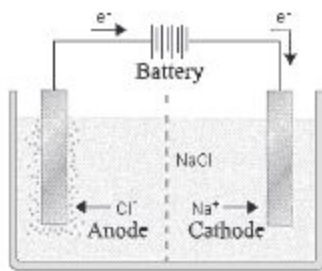
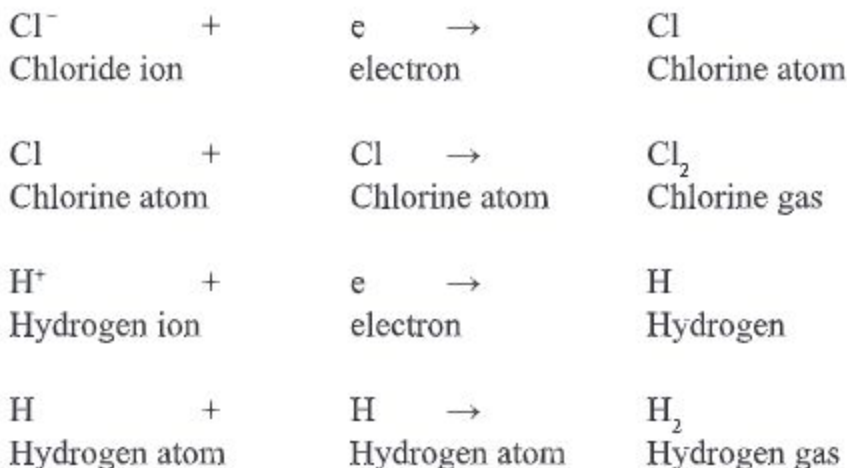

fig 8.4 : Electrolysis

Yes, the reason is that sodium chloride gets dissociated in aqua solution to produce sodium ion ( $\text{Na}^+$ ) and chloride ion ( $\text{Cl}^-$ )



This is how water getting dissociated produces Hydrogen ion and Hydroxyl ion. Due to the flow of electricity through dissolved salt connected with battery. Hydroxyl ion and chloride ion go towards Anode. Chloride ion through chemical reaction produces chlorine ( $\text{Cl}_2$ ) gas when it reaches anode. As a result we find bubbles on the anode, on the other side, Sodium ion and Hydrogen ion ( $\text{H}^+$ ) produce  $\text{H}_2$  through chemical reaction by reaching cathode. As a result the bubble of hydrogen gas becomes visible on the cathode and Sodium ion ( $\text{Na}^+$ ) and Hydroxyl ion ( $\text{OH}^-$ ) remains in the solution.



Due to the flow of electricity through Sodium Chloride solution Chlorine gas produces on the anode and Hydrogen on the cathode and Sodium Hydroxide remains in the solution.

The solutes that carries electricity in dissolved state and produces different solutes by chemical reaction due to electricity is called Electrolyte.

All materials do not produce chemical reaction due to electric current. The materials do not allow electric current to pass through in their dissolved state or in the melted form do not take part in chemical reaction. These materials are called non electrolyte. Sugar, glucose are such examples.

**New words** : Valency, radical, addition, combustion, displacement, neutralization, anode, cathode, electrolysis, electrolyte , slack lime.

#### **What we have learned at the end of this chapter**

- According to the number of valency of the element, elements form compounds by chemical bondage.
- The chemical equation reactants stay at the left side of the arrow and the products stay at the right side.
- By addition reaction more than one substance can combine to form a new material.
- By combustion reaction a substance can burn with the help of oxygen in the air and produce lot of energy as heat and light.
- In substitution reaction an element can replace another element from a compound and produce a new substance.
- A chemical reactions in which a compound is broken down to more than one new substance is called decomposition reaction.
- By chemical reaction there is transformation of energy.
- In neutralization reaction substances of opposite properties react to transform each other into neutral substances. In the combustion reaction the chemical energy generally transform into heat and light energy.
- When dry cell are used the chemical energy transforms into light or other form of energy.
- Those materials which in the dissolved state or melted state allow electricity to pass through it are called electrolyte.
- Those materials do not allow electricity to pass through them in melted or dissolved state are called nonelectrolyte.



## Exercise

### Fill in the blanks

1. \_\_\_\_\_ are created by chemical reaction.
2. The chemical reaction between calcium oxide and carbon dioxide forming calcium carbonate is a \_\_\_\_\_ reaction.
3. By combustion reaction \_\_\_\_\_ energy is produced.
4. In a dry cell the cylinder of zinc act as \_\_\_\_\_.
5. Hydrochloric acid is electric \_\_\_\_\_ substance.

### Short Answer Questions

1. What do you understand by combustion reaction? Give examples.
2. Explain what is meant by neutralizing reaction?
3. Explain what happens when water is added to lime?
4. Describe briefly the construction a dry cell.
5. Explain the main difference between electrolyte and non-electrolyte substances with examples.

### Multiple Choice Questions

1. Which one is slaked lime?
  - a. CaO
  - b. CaCO<sub>3</sub>
  - c. CaCl<sub>2</sub>
  - d. Ca(OH)<sub>2</sub>
2. From which of the decomposition reactions given below does a diver gets his oxygen.
  - a. CaCO<sub>3</sub>
  - b. CuCO<sub>3</sub>
  - c. KClO<sub>3</sub>
  - d. NH<sub>4</sub>Cl

### In the light of the paragraph below, answer the questions no. 3 and 4

Shapna took some lime in a beaker in the lab. Then some vinegar is added by a dropper. After some time she touched the beaker to find out the change of temperature.

3. What type of chemical reaction will occur between the compounds?
  - a. Combustion
  - b. Neutralizing
  - c. Addition
  - d. Substitution

4. The reaction between the compounds will produce –
- calcium acetate
  - calcium carbonate
  - water

**Which one of the following is correct?**

- |             |                |
|-------------|----------------|
| a. i & ii   | b. i & iii     |
| c. ii & iii | d. i, ii & iii |

### Creative Questions

1. Fahad and Farhan carried out some chemical reactions, which are as follows:

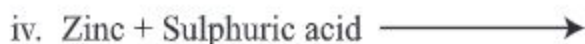
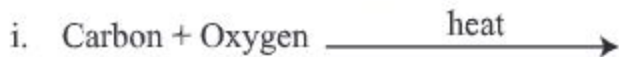

- What is the symbol of baking powder?
  - What is the type of number ii. reaction, explain?
  - Explain the generation of gas of elements in the above stimulation reactions.
  - Although the reactions i. and ii. are additive, there is some difference between them, explain
2. Rita was watching the dance of her doll by connecting the battery of her doll. At this moment the electricity went off and her younger sister Oishori brought a lighted candle.
- What is the neutralization reaction?
  - What is meant by lime water?
  - Explain the construction of Rita's battery.
  - Explain how the energy of battery of the doll and the candle transforms.

**Project:** Form a group of 4 to 5 and identify 5 chemical reactions which are closely related to our day to day life. Think whether there is transformation of energy in these reactions. If there are transformations of energy, try to find out. Make a report, what kind of transformation occurs during the transformation of energy.

## Chapter Nine

# Electric Circuits and Current Electricity

As we know, the electrons are arranged outside the nucleus of the outermost atom. The outermost electrons of the atoms in some substances are weakly bound to the nucleus. In these materials, electrons can move easily and so they are called conductors. Electric current is the flow of electrons. An electric circuit is a closed path made of conductive material through which electrons can flow. In this circuit, electrical devices and equipment can be connected in two main ways: series and parallel connections.

For current to flow through the components of a circuit, an electric potential difference must be created between its two ends.

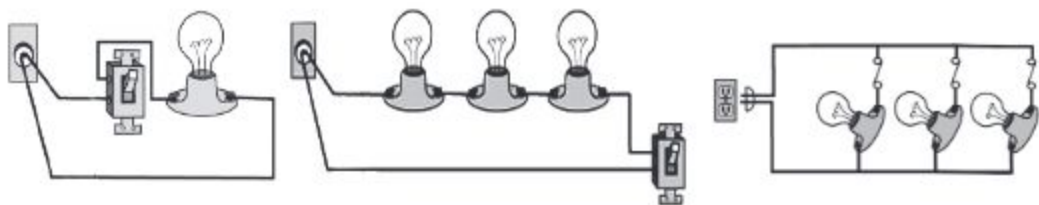

**At the end of this chapter we will be able to –**

- explain the concepts of electric potential and potential difference;
- explain the idea of AC and DC flow;
- explain the use of resistance, fuse and key in an electric circuit;
- explain the difference between current flow and voltage difference graphically;
- show the difference between current and voltage in series and parallel circuits;
- make proper use of ammeter and voltmeter in the measurements of current and voltage;
- be conscious and make other people conscious about the effective use of electricity and protection against its wastage.

### Lesson 1: Electric potential and electric current

According to modern electron theory, every metal contains some free electrons that can move freely within the material. When two dissimilar metals are connected by wires, the flow of negatively charged electrons from one metal to the other depends on a property of the metals known as potential. For this flow of electrons to occur, there must be a difference in potential between the two



metal objects. This flow of electrons continues as long as there is a potential difference between the two metals. We refer to the flow of charge as electric current. Current flows in metals due to the movement of negatively charged electrons.

### Electric current

The amount of charge that flows through any cross-section of a conductor in a given time is called electric current.

The direction of conventional electric current is opposite to the flow of electrons. Unit of electric current: The unit of electric current is the ampere, usually denoted by the symbol A.

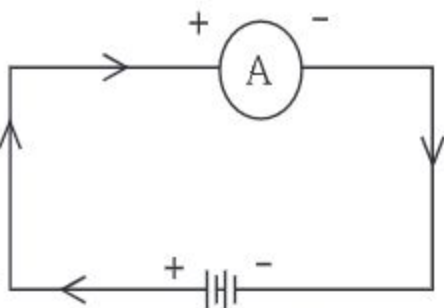

Fig. 9.1 : Electric circuit

**Electric potential:** The amount of work required to move a single positive charge from an infinite distance to a point next to a charged object is called electric potential.

### Electric potential difference

Electric potential difference is the amount of work done to move each unit of positive charge from one point in an electric field to another. If there is no potential difference between two points, no current will flow, and no work will be done.

## Lesson 2-3 : Different types of current flow

There are two kinds of current flow. (a) Unidirectional current. (b) Alternating current.

**(a) Non periodic or unidirectional current (DC):** If there is no change in the direction of the flow of current with time, it is called unidirectional or direct current. We get unidirectional current from an electric cell or battery.

Also we can get unidirectional current from a DC generator.



Fig. 9.2: Unidirectional current

**(b) Alternating current (AC):**

If the direction of current flow changes repeatedly over time, it is called alternating current (AC). When the time interval between changes of direction is constant, it is referred to as periodic alternating flow or simply periodic flow. AC is the

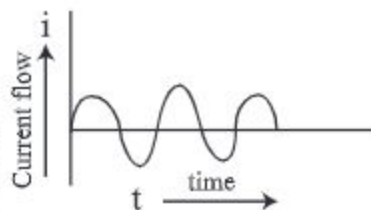

Fig. 9.3: Alternating current

standard current flow in most countries worldwide because it is relatively easy and affordable to generate and distribute. The source of alternating current is typically a generator or dynamo, and it is produced in power-generating stations across the country. The rate of directional change in periodic flow, known as frequency, varies by country. For example, in Bangladesh, the frequency is fifty times per second (50 Hz), while in the United States, it is sixty times per second (60 Hz).

**Lesson 4-5 : Resistance**

The electric current is produced by the flow of electrons. When there is a difference in the potential between two points of a conductor the free electrons are subjected to an electric force and electrons move from the low potential to high potential. But during this journey the electrons come into collision with the ions in the metallic conductor. As a result the movement of electrons is hampered and consequently the flow of current is also hampered. The property of creating obstacle by conductor is resistance. The property of creating obstacle to the flow of current is called resistance.

**Ohm's law:** The flow of current through a conductor is determined by the difference in the voltage between its two ends. The magnitude of the current also depends on the dimensions and composition of the conductor and also its temperature. At a definite temperature the current flowing through a conductor depends only on the potential difference between its two ends. The resistance of a conductor is measured from the ratio of the current flowing through the conductor and the potential difference between its two ends at a definite temperature. Besides, in case of some conductor a relation maintains between the current flowing through a fixed size conductor and the potential difference between its two ends at a definite temperature. The relation between voltage and current for a conductor of definite composition was shaped by George Simon Ohm (1789-1854). This is known as Ohm's law. Conductors that follow Ohm's formula are called Ohmic Conductor.

**Ohm's law:** At a fixed temperature the current flowing through a particular wire or conductor is proportional to the voltage difference between the two ends of the conductor.



From Ohm's law, we can see that if the voltage between the two ends of a conductor is high, the current flowing through the conductor will be large and if the voltage is low, the current will be low.

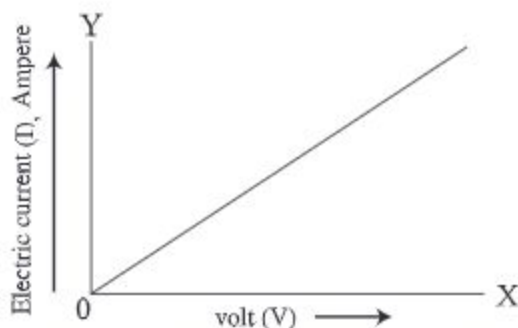

Fig. 9.4: Graphical representation of Ohm's law.

We can write Ohm's law as  $I \propto V$  and  $I = \frac{V}{R}$ , where  $I$  is the current,  $V$  is the voltage and  $R$  is the resistance of the conductor.

Thus in a particular conductor the current flowing through it is inversely proportional to the resistance of the conductor.

### The unit of resistance

The unit of resistance in SI unit is ohm. If the voltage difference between the two ends of a conductor is one volt and the current flowing through it is 1 ampere, the resistance of the conductor will be 1 ohm.

### Lesson 6-8 : Electric circuit

Just as people need a path for walking, electricity also needs a certain path. This complete or closed path of current flow is called circuit. When the two ends of a current source are connected to one or more resistors, electrical devices, or equipment, an electrical circuit forms. The circuit can be closed or opened by the help of a key or switch. If the key is closed, the circuit will be complete and current will flow. If the key is open, the circuit will not be complete and current will not flow.

In ordinary circuits the electric equipment can be connected in two different ways. They are

a) series of circuit, b) parallel circuits.

#### a) A Series of circuit

If in a circuit the resistance electric equipment or components are connected in such a way that one end of the first is joined to one end of the second and the other is joined to one end of third and so on and the successive connections made a complete circuit, then we get a series of circuit.

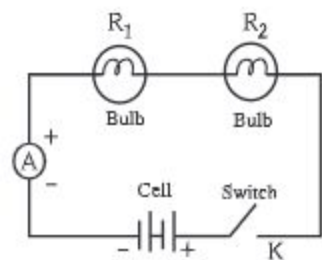

Fig 9.5: Series Circuit



In the figure resistance  $R_1$  and  $R_2$  ammeter  $A$  and key  $K$  are successively connected. The ammeter is used to measure the current and it is connected in series with the other components of the circuit. If the ammeter terminals are marked as  $+$  and  $-$ , then the positive terminal marked as  $(+)$ , must be connected to the positive terminal of the cell. In this circuit the same current flows in all the components of the circuit. But the potential difference in each part may be different.

### b) A Parallel circuit

If in a circuit more than one resistance or electric component are connected in such a way that one end of each of them are connected to one common end of a battery and other ends of all the components are connected to the other end of the battery. Then such an arrangement forms a parallel circuit. In a parallel circuit different currents may flow through the individual components but the voltage will be the same between the two terminals of each components.

In the figure the resistance  $R_1$ ,  $R_2$  and the voltmeter are  $-$   $v$   $+$  parallelly connected to each other. A voltmeter is used to measure the difference of voltage between the two terminals of a resistance. This is why a voltmeter is connected to the two terminals in Parallel to a resistance. The positive terminal of the voltmeter marked  $+$  must be connected to the positive end of the battery; otherwise you may spoil the instrument. If you connect two bulbs in series to a battery would you find the two bulbs to glow in the same way as when one bulb is connected to the battery?

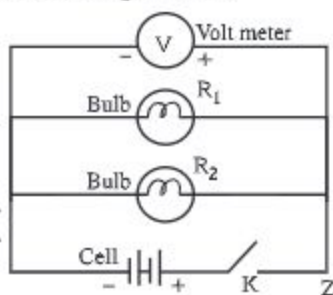

Fig. 9.6: Parallel Circuit

When the bulbs are in series the same current will flow in both the bulbs but this current will be lower than the case when one bulb is connected. As a result the intensity of light will be less when the two bulbs are in series compared to the case when only one bulb is used.

When the bulbs are connected in series and one of the bulbs is fused, the circuit will be broken and the other bulb will go off. In case the two bulbs are connected in parallel and one of the bulbs is fused, the circuit will not be broken and other bulbs will not go off. Thus in parallel connection we can put off any of the bulbs without disturbing the other bulbs. The voltage difference of the terminals of each bulb will be the same. That is, each bulb will experience the full voltage of the electric cell. As a result, the brightness of both bulbs will be the same. The brightness of the bulbs will be same whether they are connected in parallel or individually to electric cell. In our domestic uses, it is more convenient to use parallel circuits.

**Activity:** Draw the diagram of series circuit and parallel circuit on a white paper and show the direction of current flow.

## Lesson 9-10 : Ammeter and voltmeter

### Ammeter

Ammeter is an electrical instrument. With the apparatus we can directly measure the current in a circuit. Ammeter is connected to a circuit in series. In this instrument there is a moving coil galvanometer. The galvanometer is an instrument by which one can identify and measure the current in a circuit. You will know about it in more detail later on.

To see the direction in the moving coil of the galvanometer there is a needle or pointer. The pointer is calibrated in units of ampere, milliampere or microampere and can move over a scale. Like electric cell, there are two connecting terminals in an ammeter which are marked as positive and negative terminals. Usually the positive end is marked red and the negative end is marked black. The symbol of ammeter is  $\text{---} \oplus \text{---} \text{A} \text{---} \ominus \text{---}$ .



Fig. 9.7: Ammeter

### Voltmeter

The instrument by which the potential difference between two points in a circuit can be measured in ampere is called a voltmeter. The voltmeter is connected in parallel between the two points which we want to measure the potential difference.

There is a galvanometer in this instrument. To see its deflection a needle or pointer is connected to it. The pointer moves over a scale which is marked in volts. The voltmeter is connected in parallel between the two points of which the voltage difference is to be measured. As in the electric cell or the ammeter there are two terminals in the voltmeter. One of which is positive and the other is negative. Usually the positive end is marked red and the negative end is marked black. The symbol of voltmeter is  $\text{---} \oplus \text{---} \text{V} \text{---} \ominus \text{---}$ .



Fig. 9.8: Voltmeter

## Lesson 11: Fuses

If the current in an instrument that we use in our day to day life exceeds certain limit, the instrument will be spoiled. In case the current in the electric circuit of our house flows too high, it can cause even fire. To avoid such accidents some special arrangements are made in the circuit. The special arrangement is the use of fuse. Fuse is usually made of thin wire of an alloy of tin and lead. It is fixed over a ceramic structure. The wire is thin and its melting point is low. If a current flows



through it beyond a certain limit it gets very hot and melts. As a result the circuit goes off. This is how by stopping the current the fuse protects our instruments. The fuse is connected in series in the circuit.

The fuses can be with different current carrying limits. Usually fuses of 5 ampere, 15 ampere, 30 ampere and 60 ampere are used depending on the necessity. A ten ampere fuse means, no current above 10 ampere can pass through it because it will then melt and make the circuit off. For different types of instruments different fuses are used. For electric lamps, fans, televisions etc. a 5 ampere fuse is used. For electric kettle or calendar a 15 ampere fuse is used. The main fuse of the house may be 30 or 60 ampere.

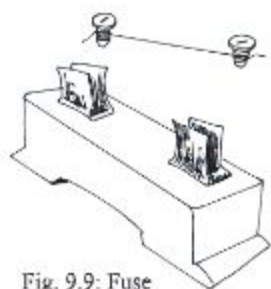

Fig. 9.9: Fuse

Try to understand the matter in more detail. Television may be damaged if currents above 5 ampere flows. Now think that what will happen if you use a 30 ampere fuse for television. It will not serve the purpose. What will happen if a fuse of 5 ampere is used for electric kettle where more than 5 ampere is needed? When you put the current on the fuse will burn. The Standard of fuse must be according to the necessity. The use of fuse greater than the needed will not serve the purpose of avoiding accidents. If we use a fuse of value lesser than the needed, it will burn too often. Some people use a number of fuse wires when the fuse wire bums. This should not be done. Because the value of the fuse then increases. For example the use of two fuses of 10 amperes will make the fuse work as a 20 ampere fuse.

### **Lesson 12: The effective use of electricity and to stop its wastage**

In our country the demand for electricity is going on increasing. Although plans are being made according to the demand, we are failing to meet the demand. In addition to this there is additional threat of climate change. This has created additional pressure on the demand of electricity. There is an increase of the number of offices, houses, shopping centers. In big buildings there is demand for air-conditioners and elevators. There is also demand for electricity in construction works. To meet the challenge there is need for efforts on the part of the government as well as on the individual level. Everybody should come forward to ensure the effective use of electricity and to stop its wastage.

To make proper use of electricity and to stop wastage of energy we can take the following steps:

- To be conscious about putting off the light, fan, and air-conditioners in houses and offices unless their uses become essential.
- To use florescence or energy saving bulbs to save electricity.



- To avoid the use of electricity for cooking and use pressure cooker which saves 25% energy.
- Not to use air-conditioner unnecessarily.
- In buying refrigerators one should avoid bigger ones than needed.
- To produce their own needed electricity in big factories using their own generators, which will save energy transmission cost.
- To take initiatives to use solar energy which is renewable.

**New words :** Electric potential, electric current, resistance, Ohm's Law, Alternating flow, electric circuit, ammeter, unidirectional flow, voltmeter, fuse

**What we have learned at the end of this chapter-**

- When two conductors with a potential difference is connected the electrical state which determines the direction of the flow of charge is what we call electrical potential.
- So long there is a difference of potential between two points on a conductor; there is a flow of current.
- If we can maintain the potential difference between the points in conductor the current will continue to flow.
- The property of a conductor which resists the flow of current through it when a voltage is applied is called its resistance.
- At a constant temperature the current through a conductor is proportional to the potential difference between the two ends of conductor.
- When the current flows in a single direction all the time, it is called direct current.
- When the current changes its direction periodically it is called alternating current.
- There are two ways of connecting electrical equipment in a circuit.. These are called series connections and parallel connection.
- With the help of an ammeter the current in a circuit can be measured directly in units of ampere.
- The instrument by which the potential difference between two points in a circuit can be measured in units of volts is called a voltmeter.
- Fuse is a special device in the circuit to avoid accidents.
- Everyone has to be conscious about the proper use of electricity and to stop the wastage of electricity.

## Exercise

### Fill in the blanks

1. If there is \_\_\_\_\_ between two conductors current \_\_\_\_\_ will occur.
2. If between the two ends of a conductor \_\_\_\_\_ is less the \_\_\_\_\_ will be less.
3. If we use a fuse of \_\_\_\_\_ to an electric kettle, this will \_\_\_\_\_.

### Short Answer Questions

1. Define Ohm's law.
2. What is the relation between the resistance and the current flowing through a conductor?

### Multiple Choice Questions

1. What is the unit of electric current?
  - a. Coulomb
  - b. Ampere
  - c. Volt
  - d. Ohm
2. What is the source of alternating current?
  - a. Battery
  - b. DC Generator
  - c. Generator
  - d. Electric Cell

### After reading the following paragraph answer questions no.3 and 4

There are two bulbs and a fan which are connected in the study room of Mina. On the other hand in their dining room two tube lights, a fan and an electric kettle are connected to the circuit.

3. Fuse of which ampere value is to use in the study room of Mina?
  - a. 5
  - b. 10
  - c. 15
  - d. 30
4. If a fuse of 5 ampere is used in dining room of Mina's family -
  - i. there will be saving of electricity.
  - ii. there will accidents occurring quite often.
  - iii. the fuse will melt, the moment the switch will be made on.

**Which of the following is correct?**

- |             |                |
|-------------|----------------|
| a. i & ii   | b. i & iii     |
| c. ii & iii | d. i, ii & iii |

**Creative Questions**

- Mr. Haque connected two 60 watt bulbs in his office room but connected a fan and a television in parallel.
  - What is flow of current?
  - What is meant by 5 ampere fuse?
  - Draw a parallel circuit with the instruments of Mr. Haque.
  - Which one of the two circuits is more convenient? Give your opinion after a comparative discussion.
- Presently there are problems in electric circuit of Mr. Kofi's house. For example, one gets a shock when the switch is made on, the bulb fuses. In such a situation a electrician was called up. He examined the current and the voltage in the circuit by using two instruments and found some faults. He suggested the members of the family about the proper use of electricity.
  - What is resistance?
  - What is meant by 10 kilo ohms?
  - Show by diagram how he connected the two instruments.
  - If the members of Mr. Kofi's family become conscious about the proper use of electricity what effect there will be on the personal level and at the national level? Explain.



## Chapter Ten

# Acid, Base and Salt

Lemon juice, vinegar, lime, antacid medicine, common salt all are very useful materials for us. Some of these are sour or acids, some of these are bases and some are salts. The chemical properties of these are different depending on their properties they are used for different purposes.

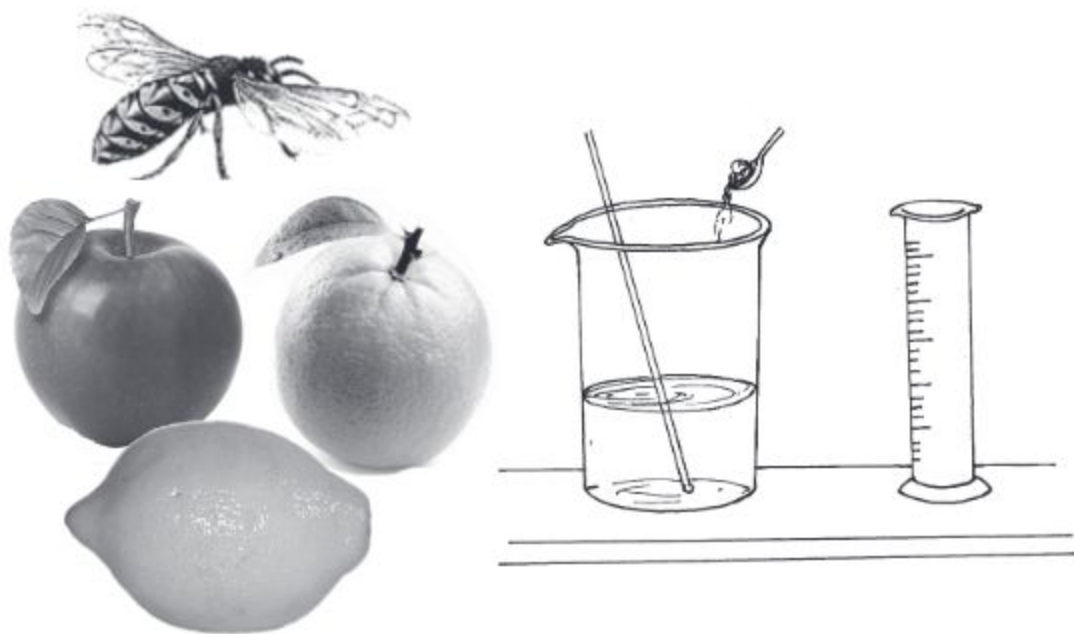

**At the end of this chapter we will be able to –**

- explain the characteristics of bases and acid;
- explain the properties of base;
- explain the properties of salts ;
- explain the neutral substances;
- use instruments properly for experimental works;
- appreciate the importance of acids, bases and salts in our life;
- create consciousness amongst the member of the group about the importance of taking safety measures during the experiments.

## Lesson 1-4: Acid, base and indicators

**Activity:** To know about acid.

**Necessary components:** Lemon juice, litmus paper, beaker, forceps

**Methodology:** Take 2-3 millilitre of lemon juice. First dip the red litmus paper into the lemon juice holding it by forceps. Did the colour of the paper change?

No, it did not. Now dip the blue litmus paper. Is there any change of colour?

Yes, the colour of the litmus paper changed from blue to red.

### Do you know the reason for the change

Litmus paper is prepared from ordinary paper by using the colour from the leaves of a tree called Lichens. Litmus papers obtained in this way look red. When the litmus paper is fermented in any alkali solution, it turns blue. On the other hand, when the blue litmus paper is treated with acid, it turns red litmus.

In lemon juice, there is Citric acid. When red litmus paper is dipped, no chemical reaction takes place, and consequently no change of colour of the litmus paper is observed. On the other hand if you dip blue litmus paper in Citric acid, chemical reaction takes place and consequently there is change of colour.



**Activity:** Divide yourselves in groups. Take some vinegar, Carambola or Orange juice instead of lemon juice. Examine them with red and blue litmus paper. Observe the change of colour.

Thus we can say that one of the properties of acids is to change the blue litmus paper into red. Do you know why just like lemon juice amloki, koromcha, carambola, lime, grape juices are sour?

The reason is that those fruits have different types of acids in them. Thus we can say acids taste sour.

A list of fruits and the acid present in each are given in the table below:

Name of the Fruit	The type of acid present
Grapes, Orange, Lemon	Citric acid
Tamarind	Tartaric acid
Tomato	Oxalic acid
Amloki	Ascorbic acid
Apple, Pineapple	Malic acid

**Activity:** To know about bases.

**Necessary components:** Lime, beaker, water, red and blue litmus papers, hand gloves, stirrer, forceps, dropper, spatula

**Methodology:** Put on the hand glove and take 5 to 10 gram of lime in the beaker using spatula. Now slowly add 100 milliliter of water to it by the dropper. Shake the mixture with the stirrer properly. Keep the mixture for ten minutes, separate out the clear solution from the top of the mixture carefully. This clear solution is lime water. Now dip in the red and blue litmus paper in turn. What change do you see in the colour of the litmus papers?

You will see that the red litmus paper turns blue in colour, but the blue litmus paper does not change its colour. Later you will know about colour change in detail.

Those materials which have chemicals like  $\text{Ca}(\text{OH})_2$  as in the lime water turn red litmus paper into blue and are called base. Sodium hydroxide ( $\text{NaOH}$ ) is a base which is a component of soap. This is used in paper and rayon industry.

**Indicator:** The litmus paper that you have used above can indicate whether a substance is an acid or base by change of colour. Materials like litmus paper which identify whether a substance is an acid or a base or none of these are called indicators. Like litmus paper methyl orange, phenolphthalein, methyl red all are indicators. These can be used to identify whether an unknown material is an acid or a base or neutral.

**Acid:** Let us look at the symbol of some acids. Vinegar or acetic acid ( $\text{CH}_3\text{COOH}$ ), oxalic acid ( $\text{HOOC}-\text{COOH}$ ), hydrochloric acid ( $\text{HCl}$ ), sulphuric acid ( $\text{H}_2\text{SO}_4$ ).

Where lies the similarities in all these acids?

Mark that in all these substances, there is one or more hydrogen atoms. These hydrogen atoms produce hydrogen ions ( $\text{H}^+$ ) in the presence of water. Thus we can say that those chemical substances are acids which have one or more hydrogen atom and produce  $\text{H}^+$  in water.

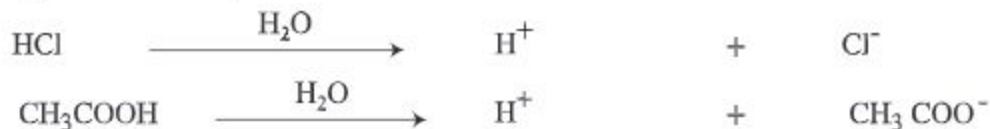

### Is methane ( $\text{CH}_4$ ) an acid

No, it is not an acid. Methane has four hydrogen atoms, it does not produce  $\text{H}^+$  in water. Now let us look at 2 bases. For example, sodium hydroxide ( $\text{NaOH}$ ) and calcium hydroxide [ $\text{Ca}(\text{OH})_2$ ].



Those chemical substances which have hydrogen and oxygen atoms and produce hydroxide  $\text{OH}^-$  in water are base.

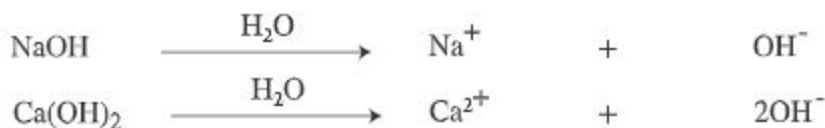

However, there are some chemical substances like calcium oxide or lime, ammonia ( $\text{NH}_3$ ) which do not have oxygen and hydrogen atoms, but they produce  $\text{OH}^-$  in water. They are also called base.

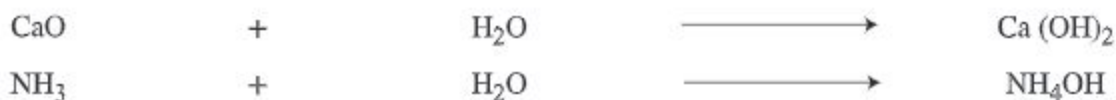

**Base:** You have known before that a base is a metal oxide or a hydroxide. There are some bases which dissolve in water. There are also some bases which do not dissolve in water. The bases which are dissolved in water are called alkali. Thus alkali is a special kind of base.  $\text{NaOH}$ ,  $\text{Ca(OH)}_2$  and  $\text{NH}_4\text{OH}$  are alkalis. These are also called base. On the other hand aluminium hydroxide [ $\text{Al(OH)}_3$ ] does not dissolve in water and that is why it is a base but not an alkali. We can, therefore say that all alkalis are base but all bases are not alkali.

You all know that when you touch soap, you feel slippery. The reason is that soap contains base. Therefore we can say that a common property of alkali and soap is that both of them are slippery. Again both bases and alkalis taste basic. It is to be remembered that we should not examine the taste of an alkali in the laboratory.

### Lesson 5-6 : Use of acids and bases

Do you know how commonly used bleaching powder is produced? It is produced by the chemical reaction between dry calcium hydroxide and chlorine gas ( $\text{Cl}_2$ ). Again the dilute solution of calcium hydroxide or lime water is used for the white wash of our buildings. On the other hand the pest of calcium hydroxide with water, known as milk of lime is used as insecticide.

Do you know why antacid is used when there is acidity in our stomach?

Antacid medicine is basically magnesium hydroxide [ $\text{Mg(OH)}_2$ ] which can be obtained both in suspension or as tablets. The magnesium hydroxide [ $\text{Mg(OH)}_2$ ] suspension is more commonly called milk of magnesia. Some times antacids contain aluminium hydroxide [ $\text{Al(OH)}_3$ ].

Acids that are formed in fruits and vegetables are called organic acids. These are edible and some are essential for our health. For example ascorbic acid is so, which we know as vitamin C. In its absence man suffers from scurvy. On the other hand, there are acids like hydrochloric acid (HCl), sulphuric acid ( $H_2SO_4$ ), phosphoric acid ( $H_3PO_4$ ), nitric acid ( $HNO_3$ ), perchloric acid ( $HClO_4$ ) which are obtained from different mineral products gathered from nature. These are called mineral acids. These are not edible. We can rather say that these are harmful for human body. Mineral acids when come in contact with human skin, can cause great damage to it.

You might have heard that some criminals in our society throw acid on human body causing serious burn. What type of acid are those? These are mineral acids.

Do you know what the punishment for throwing acid is? It is very high and can lead to death penalty.

By throwing acid, people are doing great crimes as also wasting valuable acids which could be used in industry. We have to put up protests against it and make people conscious. For this, we can make posters and distribute them among the people. We can thus try to save our society from the dangerous crimes like acid throwing and can prevent the wastage of our valuable mineral acids as well. There is no denying the fact that the use of acids in our day to day life and in industries is indispensable. The chemical that we use to clean our toilets contain acid. The goldsmith uses nitric acid when he makes ornaments of gold. We use battery in our IPS, car, and microphone and for storing solar energy in solar cells in which sulphuric acid is used. You might have known that sometimes people use carbolic acid to protect their houses from snakes.

There is acid in our stomach to digest the food we eat, this is hydrochloric acid. One of the most important components in fertilizer industries is sulphuric acid. Other than this, lot of  $H_2SO_4$  is used in the preparation of chemicals starting from detergents, paints, medicine, insecticide, paper, explosives and rayon.

The state of progress of a country in respect of its industrial development is usually judged by the quantity of  $H_2SO_4$  it uses.

HCl is used in steel mills, medicine industries, leather industries etc.  $HNO_3$  is used in fertilizer industry for the production of explosives, for extracting precious metals like gold from the mine and with fuels for rockets.



## Lesson 7-10: Some important properties of acid and alkali

**Activity:** Observing the reaction of hydrochloric acid with limestone

**Necessary Components:** Limestone, spatula, dilute hydrochloric acid, dropper, apron

**Methodology:** Put on the apron. Grind the limestone. Take the clay powder in the spatula. Now go on adding dilute hydrochloric acid to the powder of clay in the spatula drop by drop. Do you find any change? Is there bubbles created? Yes, there are bubbles creating foam. This happens because, when dilute hydrochloric acid is added to clay stone ( $\text{CaCO}_3$ ), there is a chemical reaction between calcium carbonate and hydrochloric acid. This produces calcium chloride and carbon dioxide gas, which form bubbles. When the produced carbon dioxide is gone, we see a transparent solution of calcium chloride in water.

All acids react with carbonate like hydrochloric acid and produce carbon dioxide.



You will be surprised to know that often this property of acids is used to produce carbon dioxide to extinguish fire.

Can you say what reaction will take place between baking powder ( $\text{NaHCO}_3$ ) and hydrochloric acid? The reaction between baking powder and hydrochloric acid produce sodium chloride, water and carbon dioxide gas.

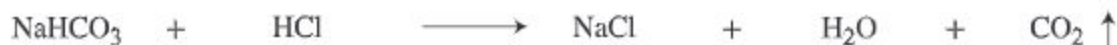

You have learned in your lower class what reaction takes place when lemon juice or vinegar is added to baking powder. Do you remember it? Write down the reaction that takes place in this case.

**Activity:** To observe what happens when acid is added to metals.

**Necessary components:** Zn as metal, dilute hydrochloric acid, spirit lamp, test tube, apron

**Methodology:** Put on the apron. Fill half of the test tube with dilute hydrochloric acid. Add a little amount of zinc to the test tube. Do you find bubbles coming out? If not heat the test tube lightly. Do you now find bubbles of gas?

This is bubble of hydrogen gas which is produced by the reaction between zinc and hydrochloric acid. You can test whether the gas is hydrogen by an experiment. Take a lighted match stick near the open end of the test tube. What do you see? It is burning with a sound. If it was any gas other than hydrogen, it would not produce any sound.



Like hydrochloric acid, any other acid produces hydrogen gas by reacting with metals.



**Activity:** To observe the reaction between acid and lime water.

**Necessary components:** Lime water, sulphuric acid, beaker, red litmus paper, stirrer, forceps, dropper

**Methodology:** Prepare lime water. Take 10 millimeter of lime water in a small beaker. Now dip red litmus paper in the lime water with the help of the forceps. The litmus paper turns blue from red. This proves that lime water is alkaline. Now add dilute sulphuric acid to it slowly using the dropper and go on stirring. By dipping litmus paper in the solution of the beaker, find out what type of change in colour occurs. In this way, go on adding  $H_2SO_4$  gradually and continue the test with litmus paper. At one state you will find that no change of colour occurs.

Why the colour of litmus paper is not changing?

The reason is that the calcium hydroxide [ $Ca(OH)_2$ ] present in lime water by reacting with the added sulphuric acid  $H_2SO_4$ , produce calcium sulphate and water. As a result the amount of  $Ca(OH)_2$  decreases gradually. When all the amount of  $Ca(OH)_2$  completes its reaction with  $H_2SO_4$ , the litmus paper no longer changes its colour.



Here the produced calcium sulphate is a salt. Thus we can say that base and acid reacts to produce mainly salt.

Let us look at the reaction between some other bases and acids and the produced salts



It is to be noted that salt is produced not only by the reaction between base and acids. Other reactions may also produce salt. For example, reactions between metals and acids may produce salts.



Again acid reacting with carbonate, which is a salt, can produce salt.



## Lesson 11-13 : Acid, alkali and salt identification

**Activity:** To observe if there is change of colour on litmus paper when dipped in the ordinary salt solution in water.

**Necessary Components:** Beaker, stirrer, table salt, water, red and blue litmus paper, forceps

**Methodology:** Take 50 millilitre water in a beaker and add 10-15 gram of table salt to it. Stir it thoroughly with the stirrer. Now using the forceps, first dip the blue litmus paper and then the red litmus paper in the salt solution. Do you find any change in colour of the litmus papers? No change of colour will be observed. What is the reason?

The reason is that there is no acid or base in the solution. If there was acid, the blue litmus paper would turn red and if there was any base, the red litmus paper would turn blue.

This is only table salt dissolved in water, which is a neutral substance and therefore is neither acidic nor alkaline to cause a change in colour. There are other salts which are neutral like table salt which means these will cause no change of colour of litmus paper.

Sometimes, due to impurity, there can be acid or base in polluted water. In those cases there can be change of colour of litmus paper, although water is neutral in pure form.

**Activity:** How to examine the acid or base prepared from the extracts of flowers and vegetables.

**Necessary components:** Petals from Joba, Baganbilash and yellow Krishnochura and leaves from cabbage, Beets, creeping herb, six beakers, stirrer, water, bunsen burner or gas burner, filter paper, bottle, paper and pencil, lemon juice, vinegar, sour curd, lime water, baking powder, soap water, sodium hydroxide, hydrochloric acid, a piece of glass, dropper

**Methodology:** Collect the samples of the flowers and vegetables listed above. Taking samples from the individual flowers and vegetable in separated beakers add appropriate amount of water and then heat them in a burner. When the water reduces to half the original volume, cool down the mixtures. Filter and put the extracts in different bottles with specific marks. Now put lemon juice, lime water, sour curd, vinegar, soap water, baking powder, HCl, NaOH in different test tubes and mark them. Taking little extracts from each bottle add them to each test tube and shake well. Do you find any change in the colours of the extracts? Make a chart with identification of the substances as found out by the change of colour to red or blue. From this chart you can see which materials are acids and which materials are bases.

Write down in change of colour for each extract. Now examine each material with red and blue litmus paper and find out which of them are acids and which of them have the characteristics of a base. Materials are classified as belonging to the same group when they respond in the same way through the change of colour.

**New words :** Acid, base, indicators, litmus, lime water, antacid

### **What we have learned at the end of this chapter-**

- The materials which produce hydrogen ions when dissolved in water are sour or acids.
- Acids turn blue litmus paper to red. Acid tastes sour.
- Metallic oxide or hydroxide is bases. Bases turn red litmus paper to blue.
- Alkalis are those bases which dissolve in water. Bases taste basic.
- Whether a material is an acid, a base or neutral substance can be judged from the change of colour indicators.
- Salt is a neutral material which produced by the chemical reaction between an acid and a base.
- From the reaction of acid with metallic carbonate or bicarbonate - salt, water and carbon dioxide are produced.
- Through the reaction between acids and metals, salt and hydrogen gas are produced

## **Exercise**

### **Fill in the blanks**

1. Acids produce \_\_\_\_\_ in water.
2. Alkali is a kind of base which are \_\_\_\_\_.
3. All alkalis are \_\_\_\_\_ but all \_\_\_\_\_ are not alkalis.
4. By the reaction of acids and bases \_\_\_\_\_ are produced.
5. Antacids are \_\_\_\_\_ like materials.



**Short Answer Questions**

1. What is the main difference between an acid and a base?
2. Explain the sentence -all alkaline are bases but all bases are not alkalis.
3. What type of chemical reaction occurs when carbon dioxide is introduced in lime water? Describe with corresponding reaction.
4. Does litmus paper change colour due to salt or pure water? Give explanation in favour of your answer.
5. what do you understand by indicators?

**Multiple Choice Questions**

1. What type of acid is there in tomato?
  - a. Acetic acid
  - b. Oxalic acid
  - c. Maleic acid
  - d. Citric acid
2. Which acid is edible?
  - a.  $\text{HNO}_3$
  - b.  $\text{HCl}$
  - c.  $\text{H}_2\text{SO}_4$
  - d.  $\text{CH}_3\text{COOH}$

**Read the following sentence and give answers to questions no.3 and 4**

Adil once carried out a reaction between zinc and hydrochloric acid.

3. The compound produced by the reaction is -
  - i. salt
  - ii. base
  - iii. alkali

**Which one of the following is correct?**

- a. i & ii
  - b. i & iii
  - c. ii & iii
  - d. i, ii & iii
4. What will be produced if there is a reaction between the carbonate containing salt and the second compound?
    - a.  $\text{H}_2$
    - b.  $\text{O}_2$
    - c.  $\text{CO}_2$
    - d.  $\text{Cl}_2$

**Creative Questions**

1. Farah likes only fatty food. Recently he is often feeling stomach pain. When he met the doctor he was told that he has got acidity. Doctor besides advising him about changing his food habit, prescribed him a medicine.
  - a. What is salt?
  - b. What is meant by milk of lime?
  - c. What type of medicine did the doctor prescribe and why did he do so?
  - d. What type of compound is in the component that is producing the acid referred in the paragraph? And why? Explain.
2. Mansura occasionally chews betel leaves. One day she put lime in water in a pot. After some time, she observed that the pot has become hot. She also marked that when she was taking some lime from the pot, the lime water turned cloudy due to her breath reaching the lime water.
  - a. What is Alkali.
  - b. Why the lime water turned cloudy?
  - c. Explain the various uses of the watery compound in Mansura's pot.
  - d. Explain the fact that the first compound in the paragraph shows the properties of both an alkali and base.

**Task:** Give a presentation of the list that you have prepared on the various acids, bases and salts that are used in our households.

## Chapter Eleven

# Light

When a ray of light crosses obliquely from one transparent medium into another transparent medium, it is bent at the interface. This is refraction of light. In this chapter we will discuss various day to day phenomena where refraction of light is involved. These will include the total internal reflection and its application in the use of optical fibres. We will also discuss how a magnifying glass works and compare the function of our eyes with the function of a camera.



**At the end of this chapter, we will be able to-**

- discuss different phenomenon of refraction in daily life by drawing diagrams;
- explain total internal reflection ;
- explain how optical fibers work;
- explain the function of magnifying glass ;
- explain how spectacles work;
- explain the functions of camera and our eyes;
- appreciate the usefulness of light in performing the different activities in daily life.

### **Lesson 1: The refraction of light**

Have you seen your image in a window glass? You must have marked that your image in the window glass is rather indistinct. Do you find a difference between this image and the image you see in the mirror? Why the image in the window glass is dull? The reason is that glass is transparent and most of the light falling on it passes through. Only a small fraction of the incident light is reflected back which forms the dull image.

Let us now see in detail how the direction of light changes when passes from one medium into another. First of all we begin with the following activity:



**Activity:** The concept of refraction

**Necessary components:** A long pencil, a drinking glass with water in it

**Methodology:** Take a glass which is 3/4 filled with water. You now put the pencil in the partially filled glass of water in an inclined way like the figure 11.1. How does the part of the pencil look under the water?

Observe the immersed part of the pencil. Write down the observed results. We know that we can see an object only when light reaches our eyes reflected from the object. You surely have seen that apparently the immersed part of the pencil look shorter, thicker and broken along the bottom of the glass.



Fig. 11.1 : Refraction of light

In the above experiment light from the bottom of the immersed part of the pencil reaches us after refraction. Before the light from the immersed part of the pencil reaches our eye it passes from the denser transparent medium water to rarer medium air and is deflected in the surface. If light passes straight through two different medias, the pencil will look straight certainly. But you observed that it seemed broken under water. The apparent bending of the pencil gives evidence that light is refracted at the surface between the two different Medias. This change of direction of light is known as refraction of light. Light follows a straight path when the medium is fixed and transparent. But light change its direction as soon as it enters into another medium. This change will take place according to the density of the changes medium. It is to be noted that if light falls normally on the surface, there will be no change of direction of light.

### Lesson 2-3: Laws of refraction of light

Light rays follow the laws of refraction. Do the following experiment first?

**Activity:** Refraction of light of a glass slab.

**Necessary components:** Pins, glass slab, drawing board

**Methodology:** Fix a sheet of white paper on the drawing board. Put the glass slab at the center of the white paper and draw its boundary line. Now remove the glass slab and draw an incident ray AB. Fix two pins P and Q approximately 5 cm apart on the line AB. Put back the glass slab in the previous position and try to look at the pins P and Q from the opposite side of the slab. (Teachers help may be needed). Now put two pins R and S on the opposite side in such a way that if you look from this side all the pins PQRS appear to be in a straight line through the slab. Remove the slab and draw the

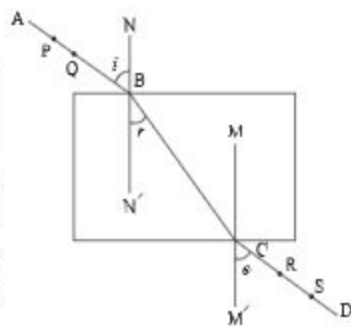

Fig. 11.2 : Refraction of light with respect to glass slab.

line CD through the points marked by the pins R and S. Draw the refracted ray BC, the normals  $MM'$  and  $NN'$  as in the figure. Using a protractor draw the incident angle  $ABN$ , the refracting angle  $CBN'$ , and the emergent angle  $DCM'$ .

From the above experiment what observations can you make? Here light is entering from rarer medium air to the denser medium glass. From the measurement of angles it is observed that the angle of incidence  $i$  is greater than the angle of refraction  $r$  and is equal to the emerging angle  $e$ . What conclusions can you draw from these?

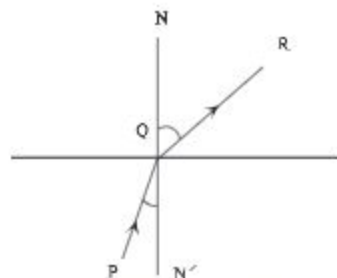

Fig.11.3: Refraction of light from dense medium to rarer medium.

- When a ray of light enters from rarer medium to a denser medium then it bends towards the normal. In this case the angle of incidence is greater than the angle of refraction.
- When the light ray is reflected from one medium (like air) into another medium (like glass) and finally emerge out in the original medium angle of incidence is equal to the angle of emergence.
- The incident ray, the refracted ray and the normal drawn at the incident point on the surface separating the two media, all lie in the same plane.
- In addition to this it is observed from the above experiment that light rays in passing from denser medium to rarer medium bends away from the normal. In this case the angle of incidence is smaller than the angle of refraction.
- When the ray of light is incident along the normal, then the angle of incidence, the angle of refraction and the angle of emergence are all zero. In this case there is no change in direction of the incident ray.

### Lesson 4-5: Practical application of refraction

You will find the application of refraction in the following cases

- 1) When a straight rod is immersed obliquely in water and looked at from above, how the part of the rod that is under water will appear? If you observe carefully you will see that the rod is appearing smaller, thicker and raised upwards. In fact it appears so because of refraction. As you see in the figure, light is refracted from the denser medium water into the rarer medium air and enters your eyes. Every part of the emerged rod is raised upwards. As a result the rod appears lifted upwards and reduced in lengths and increased in diameter.



Fig.11.4: Refraction of light



2) Take a steel mug or a ceramic cup. Put a coin in the mug or in the cup. Keep your eyes in such a position that you just fail to see the coin. If now somebody pours water in the cup, the coin will be come visible at one stage. It has been possible due to refraction phenomenon. Due to refraction light bends in passing from the denser medium water into rarer medium air and create a virtual image of the coin which you see.



Fig.11.5: Virtual image of a coin due to refraction of light

(3) Did you ever hunt fishes? Does a fish stay at the position at which you see the fish in transparent water? Not at all. In fact, we observe the virtual image of the fish. The fish stays at a position which a bit lower than where it appears to be. If you hunt the fish with a spear, you have to aim it at a deeper and farther position than its apparent position. Something similar happens about the appearance of steps under transparent water. The real position of a step under water is lower than it appears when we look obliquely.

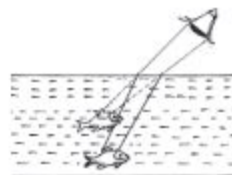

Fig.11.6: Change of image position of fishes due to refraction of light

People failing to realize it, may have a fall. Such events you can see if you visit the Sera Island of saint martin. The water there is very transparent. Stones and algae under water appear much closer to the eye than they really are. This happens due to refraction of light.

## Lesson 6 -7: Total internal reflection and critical angle

When a ray of light enters a rarer medium from a denser medium, the refracted ray bends away from the normal drawn at the point of incidence of the ray. As a result the angle of refraction becomes larger than the angle of incidence. In this way as the angle of incidence increases the corresponding angle of refraction increases. For a

particular combination of such pair of media there is a particular value of the angle of incidence, which in this case must be smaller than  $90^\circ$ , the corresponding angle of refraction becomes  $90^\circ$  which means the refracting ray passes along the surface of separation of the two media. The angle of incidence which corresponds to this situation is called the critical angle. Now, what will happen if the angle of incidence is greater than the critical angle? The angle of refraction can not naturally be greater than  $90^\circ$ .

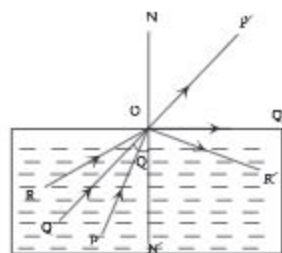

Fig. 11.7: Total internal reflection and critical angle



It has been observed experimentally that in this case the light ray instead of being refracted is reflected back in the medium from the surface level. Thus the boundary surface here acts as a reflecting surface and this reflection occurs according to the laws of ordinary reflection. This phenomenon is called total internal reflection. This means that the light ray from denser medium in this case is reflected at the boundary surface following the ordinary law of reflection and returns back totally to the denser medium.

According to the figure the angle of incidence corresponding to the incident ray PO is less than the critical angle and the corresponding reflected ray is  $OP'$ . For the incident ray QO the angle of incidence is equal to the critical angle, and the corresponding reflected ray is  $QO'$  which is traveling along the boundary surface. This means the corresponding angle of refraction is  $90^\circ$ . For the ray RO, the angle of incidence is greater than the critical angle. In the case the ray  $OR'$  is reflected back by the total internal reflection. Now the question is what difference is there between ordinary reflection and total internal reflection?

In the case of ordinary reflection there is always some partial refraction along with the reflection. But in the total reflection it is observed that the incident ray is totally reflected.

### **The conditions for total internal reflection**

- 1) It occurs only when the light ray goes from a denser medium to a rarer medium.
- 2) The angle of incidence in the denser medium must be greater than the critical angle corresponding to the pair of media chosen.

## **Lesson 8: Optical fibre and magnifying glass**

### **Optical fibre**

The optical fibre is a very thin fibre of glass. It is even thinner than human hair and is flexible and extremely transparent. It is used as the carrier of the light rays. When light rays enter in this fibre, they undergo repeated total internal reflection at the walls of the fibre. This process continues till the rays reach the other end of the fibre. Usually doctors use a bundle of optical fibres in a flexible tube through which light rays are guided to examine different internal parts of the human body like the stomach or colon. Another use of optical fibre is optical communication. Since light consists of high frequency electro-magnetic waves, it can carry much more information. In optical fibre the loss of signal strength is very low and one can send information to long distances and along curved paths by using it.

### Magnifying glass

A magnifying glass is a type of convex lens that makes objects appear larger. When an object is placed within a certain distance of a convex lens and viewed from the opposite side, an upright, magnified, and virtual image of the object is seen. The closer this image is formed to the eye, the larger the eye's viewing angle will be, making the image appear larger. However, if the image is formed closer than a point known as the "near point" (the closest distance at which the eye can see clearly), it will no longer appear sharp. When the image forms at this near point, it becomes most clearly visible to the naked eye.



Fig 11.8 : Magnifying glass

When a beam of light parallel to the lens's axis strikes a convex lens, the point where the light rays converge is called the focal point. The distance from this focal point to the lens along its axis is known as the focal length. To magnify objects or text that are hard to see with the naked eye, a convex lens with a short focal length is used. This lens, enclosed in a suitable frame, is known as a magnifying glass, reading glass, or simple microscope. This device doesn't offer a high degree of magnification.

With the teacher's guidance, you can observe this type of magnifying glass.

### Lesson 9-10: Human eye

The eye is one of our five sense organs. We see things by our eyes. The working of the human eye is similar to the working of a camera. The special parts of a human eye are shown in the picture. It's main parts are described below.

- Eye-ball:** In the cavity of the eye there is a spherical object which can be rotated within a certain limit. This is known as eye ball.
- Sclera:** This is a white covering of the eye-ball which is hard, fibrous and opaque. It protects the eye from external harmful effects and preserves the shape of the eye.
- Cornea:** Frontal part of the sclera is called cornea. This part of the sclera is transparent and is bulged outwards more than other parts.
- Choroid:** It is a black membrane covering the inner body of sclera. Because of its blackness, the light entering the eye is not reflected.
- Iris:** It is an opaque membrane which stays just behind the cornea. This membrane can be of different colour like blue, deep brown, black etc. for different persons.

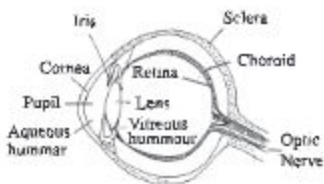

Fig. 11.9: Internal Structure of Human eye



**f) Pupil:** It is a circular hole at the centre of the cornea which is connected to muscular cells. The size of the aperture of the pupil can be changed by the expansion and shrinkage of the muscles attached to it.

**g) Crystalline convex lens:** This is a convex lens made of soft jelly like material which is situated behind the cornea.

**h) Retina:** It is a light sensitive rose coloured translucent membrane located behind the eye-ball. When light falls on retina it creates some excitements in those nerves and produce the sensation of sight in the brain.

**i) Aqueous hummour and vitreous hummour:** The space between the lens and the cornea is filled with some kind of transparent watery substance. This is called aqueous hummour.

The space between the lens and the retina is filled with jelly like material. This is called vitreous hummour.

## Photographic camera

This instrument is used to take photographic pictures on photographic plates with the help of lenses. This is why it is called Photographic Camera or in Short Camera. The different parts of the camera are: 1) Camera Box, 2) Camera lens, 3) Aperture, 4) Shutter, 5) Screen, 6) Photographic Plate, 7) Slide.

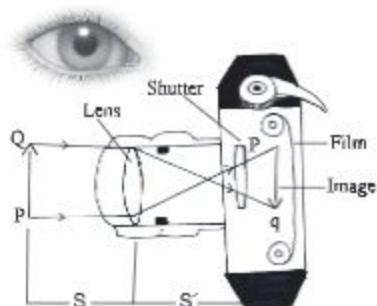

Fig 11.10: Photographic Camera

**The working of a camera:** Before taking the photograph of an object the ground glass screen of the camera is directed to the Object PQ and the shutter is opened. Now by adjusting distance between the lens and the screen the image Pq of the object is focused on screen which is placed opposite to the object. The proper brightness of the image is obtained by adjusting the aperture. Now removing the ground glass screen the shutter is closed and the ground glass is replaced by the photographic plate. Now, the cover of the slide is removed and the photographic plate is exposed to a definite amount of light through the shutter and aperture. After that the aperture is again closed. This controlling of light is called the exposure. The incident light causes chemical reaction to the silver halide grains contained in the emulsion of the photographic plate.



Now the slide is covered and the photographic plate is taken to the dark room, and then the photographic plate is taken out from the slide and the plate or film is kept immersed in a chemical solution called developer. The parts of the film are chemically reduced from the silver halide to metallic silver, the reduction takes place. Those parts of the object which emitted more light, the more quantity of silver is stored to those parts of the plate, darkens the corresponding parts of the film proportionately. The thickness of the coating of silver depends on the brightness of light and duration of exposure. After washing the film it is dipped in hypo (Sodium thiosulphite). As a result those parts of the film which had not been exposed to light get their silver halide dissolved. The film is then washed in water. Thus we get the negative picture of the photograph of the object. To get the positive of the picture of the negative film it is placed over a photographic paper coated with silver halide and exposed to the light for a short time. After this the paper is washed in hypo as before and the positive picture is obtained after washing and drying.

#### A comparison between an eye and a camera

Camera	Eye
1) It is a light proof closed box which is painted black inside. For this black colour light incident on it is not reflected.	1) The eye behaves as a light proof enclosure. Its walls are black so light falling on it is not reflected.
2) Using the shutter the lens of the camera can be kept exposed to light for any length of time.	2) With the help of the eye lid, the eye lens can be kept exposed to light but i lid cannot kept exposed to light for any length of time.
3) The amount of light needed to form the picture can be controlled by adjusting the circular aperture of the camera.	3) Depending on the intensity of light the aperture of the cornea is automatically adjusted to allow the necessary light to form the image.
4) A camera has many lenses and each lens has a specific focal length. The lens-use functioning focal length can be changed by moving the lens backward and forward.	4) By adjusting the muscles attached to the eye lens, its focal length can be changed by changing its curvature.
5) The image of the object is formed by its convergent lens.	5) Cornea, aqueous humour eye-lens, vitreous humour together make a convergent lens, like system to form the image of an object.
6) A real inverted and reduced image of the object is formed on the photographic plate.	6) An real inverted and reduced image of the object is formed on the light sensitive retina.

**New words:** Refraction of light, total internal reflection, critical angle

**What we have learnt at the end of this chapter-**

- In a certain transparent medium light propagates in a straight line but it enters a second medium of different it bends by an amount which depends on the optical density of the second medium.
- When light falls perpendicularly and transparently on the surface separating the two media, its direction does not change.
- When light enters from a rarer medium into a denser medium it bends towards the normal drawn at the point of incidence on the surface separating the media. When light enters from the denser medium into a rarer medium it bends away from the normal.
- For total internal reflection the angle of the incidence in the denser medium must be greater than the critical angle that corresponds to the two media.
- There are many similarities between the working procedure of a human eye and that of photography camera.

### Exercise

#### Fill in the blanks

1. The path of light when it enters a different medium depends on \_\_\_\_\_
2. The ray of light that falls along the normal to the surface emerges \_\_\_\_\_
3. In total internal reflection, the angle of \_\_\_\_\_ is greater than the \_\_\_\_\_

#### Short Answer Question

1. Why light changes direction when it enters in a different medium?
2. What is critical angle? When is it formed?
3. What are the differences between a human eye and a camera?

#### Multiple Choice Questions

1. What is the term used for the sclera in front of the eye?
  - a. Lens
  - b. Retina
  - c. Cornea
  - d. Iris
2. Optical fiber is used for -
  - i. fuel
  - ii. examining stomach
  - iii. telecommunication

#### Which one of the following is correct?

- a. i & ii
- b. i & iii
- c. ii & iii
- d. i, ii & iii

Answer questions no. 3 and 4 from the following figure

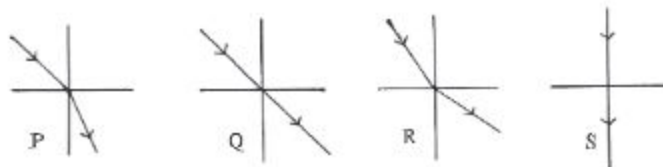

- In which figures light is propagating from denser medium into rare medium?
  - P
  - Q
  - R
  - S
- In which of the figures the angle of incidence is equal to the refracting angle?
  - P & R
  - Q & R
  - Q & S
  - S & P

### Creative Questions

- One day Anis went to a pond to take a bath. He put his feet on the visible steps under transparent water. But since the steps were at a greater depth than they appeared to, he fell down. On the other hand his younger brother is catching fish in the pond using spear failed to throw the spike correctly.
  - What is refraction of light?
  - What is the cause of change in the direction of light?
  - Explain why Anis fell in the pond?
  - What type of trick makes Anis' brother successful in hunting the fish? Explain your answer.

2.

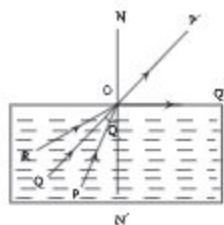

- What is total internal refraction?
- What is meant by optical fiber?
- Explain critical angle in the figure.
- Explain the path of Ray RO with diagram.



## Chapter Twelve

# The Outer Space and Satellites

We can see the sun in the sky at day time. The cloudless sky of night surprises us. In a clear night sky there is the moon and innumerable twinkling stars. We are charmed by their beauty. Above us there is the limitless sky and the infinite outer space. The sun, the moon, the planets, the stars, the Milky Way, the galaxies, the outer space– altogether make our universe. Everything that belongs to the universe is known as the object of the firmament. In this chapter, we will discuss about the universe.

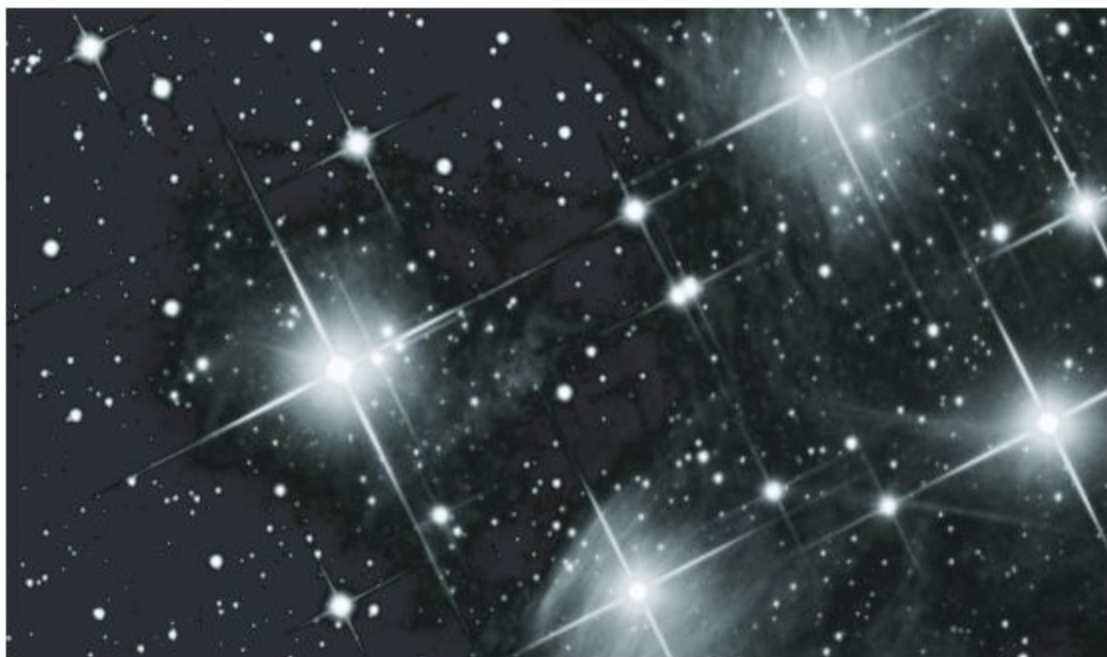

**At the end of this chapter we will be able to–**

- explain the outer space and the universe;
- explain natural and artificial satellites;
- explain the movement of satellites in the orbit;
- describe the uses and importance of artificial satellites;
- appreciate the benefits derived from artificial satellites.

**Lesson 1 : The outer space**

We see the sun as the brightest object in the sky at day time. You should not however, look at the sun directly. Because it can cause great harm to your eyes. When you look up at the sky at a clear night, what do you see? The dark night sky is dotted with twinkling points of light which we call stars. These may as well be in the sky as a thin arc or as a full circle of light. The brightest planet is venus and the reddish planet is Mars. Except for the outer planets, all other points of light are stars. Sometimes you can see a faint glowing band across the overhead sky when it is clear and dark enough. It is made up of stars too far away to be seen as separate points of light. This band is known as Milky Way. If we look through the telescope, we see many more objects in the sky. The planet Jupiter shines in the sky with its satellites. Outer space is the vast extension of space in which all objects of the sky including the planets, stars, and galaxies have their existence. The outer space is mostly empty in which the material objects in different forms are moving like our the Earth.

**Where does the outer space begin?**

The atmosphere of the earth rotates along with it. This is why the atmosphere is taken as a part of the earth and not as a part of outer space. Thus the outer space begins, where atmosphere ends. The greater portion of the atmosphere exists near the earth. The air surrounding the earth gets thinner as you go upwards until there is none at all. When we go about 160 km above the ground, the space becomes almost empty. Although space itself is almost empty, there are many exciting things out there such as planets, stars and galaxies. How far the outer space is extended? In physical science we believe in the observable world. Space has no meaning unless there are events or the existence of matter in it. Thus the extension of space in the physical sense is the farthest point in space where from information can reach us. The most distant galaxy from which light can reach us determines that size of the universe as also the limit of space.



Fig. 12.1 : Earth, atmosphere and the outer space



In the old concept, space was infinite in its extension. But in modern science the most distant galaxy from which light can reach us determines the size of the universe and also the limit of space. You will see that this limit is very very large but finite.

**Activity:** What is space? Know it with the help of different books and magazines. What are the things are there in space? Write down in your note book. Compare your findings in a group and present in the class room (Teacher will help make a group).

## Lesson 2: The Universe

### How the universe is defined

The Universe is composed of all existing matter and space as a whole. The earth, the planets, stars far and near, comets, galaxy, small insects, dust, visible and invisible things all comprise the Universe. Nobody knows how big is the universe. The shape and size of the universe is unknown to all. Many scientists think that there is no beginning and ending of the universe. Again some people believe that the universe has size and shape. Humans are discovering new information about the universe now and then. But much of it is still beyond knowing.

Although many things are not known to us, the existence of matters in some parts of the universe is higher than another part. The matters concentrated on a large volume in some parts of the universe is called galaxy or star world. Galaxy is a large group of planets and stars. Our earth exists in the galaxy of Milky-Way. There are crores of galaxies in the universe where exists crores of stars.

The galaxies move in groups in the outer space. The stars of the galaxies seem very near in comparison to the unlimited outer space, but it is not true. They are so far from one another. Let us think about the distance among them. We know that light runs about 0.3 million km. way per second. The distance between the earth and the sun is about 150 million km; the sun light takes approximetly 8 minutes 20 seconds to reach the earth. On the other hand, the sunlight takes more than 4 years to reach Alpha Centerio, the nearest star from the sun. Light takes a few million of years to reach from a farthest star to another fastest star. Now you can realize that what is the distance from one star to another star and how mammoth the univers is!

The solar system exists in the galaxy named Milky-Way. The stars are seen, twinkling and shining from the earth. Each of the stars is a mass of burning gas and so it has light and heat. The stars of the universe are divided into different colours like red, blue, yellow etc. according to the intensity of their light. Very large stars are red, medium stars are yellow and small stars are blue. The stars of the universe are divided into different colours like red, blue, yellow etc. according to the intensity of their light. Very large stars are red, medium stars are yellow and small stars are blue.



## How the Universe is created?

From the available evidence on the age of the universe, Astronomers think that the Universe started with a massive explosion, this is called Big Bang Theory. According to this theory, the universe was once extremely hot and infinitely dense at points. According to the Big Bang theory, the universe spontaneously expanded very rapidly. It happened about 13.75 billion years ago. A huge explosion sent everything racing outwards in all directions. Before the Big Bang everything was packed incredibly close together to a point of high temperature and density. Over time it has expanded into the Universe we see today.

When scientists look at distant galaxies they see that other galaxies are moving away from our galaxy. More distant galaxies are moving away faster. In fact all the galaxies are moving away from each other. We say that the Universe is expanding. All the astrologers, including the famous physicist Stephen Hawking of the present time, Have expressed their opinion in favour of this theory.

### Lesson 3 : Natural Planet or Satellite

The galaxy to which we belong, you know, is the Milky-Way. In this Milky-Way the sun is located along with its family members. They together form the solar system where 8 planets are revolving round the sun. The objects which revolve round the sun are called planets. These planets are Mercury, Venus, Earth, Mars, Jupiter, Saturn, Uranus and Neptune.

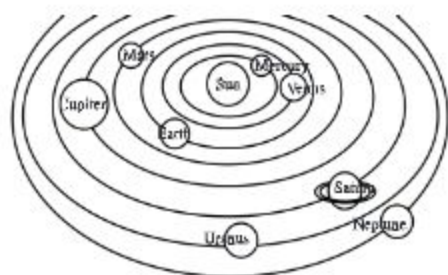

Fig 12.2: Solar System

Some of the planets have more than one satellite. The objects which revolve around the planets are called satellites. For example, the moon is revolving round the Earth and Earth's Satellite. So, the earth is a planet of the sun and the moon is a satellite of the earth. Do the activity below and you will understand the motion of planets and satellite.

**Activity:** Understanding about the motion of the planets and Satellites.

**Methodology:** Stand in an open space. Ask one of your friends to stand at a definite position. Draw a big circle with your friend at the center. You take your position at one point on the circumference of the circle. Ask another of your friends to move in a smaller circle with you at the center. Now if you move in the bigger circle with your first friend at the center of the circle and your second friend revolves around the smaller circle with you at its center, your first friend can be taken as the sun, you can be considered the earth and your second friend can be considered the moon.

Astronomers think that a few cosmic clouds revolved around a star when the planet was born. They condense due to the force of gravity and eventually solidify and transform into planets. In this way, again satellites are formed around the planet. These satellites are natural satellites. The planets and satellites do not radiate light or heat because they are not big enough to start nuclear reaction as happened in stars. Sunlight is reflected falling on them. The Earth has 1 satellite, Mars has 2 satellites, Jupiter has 67 satellites, Saturn has 62 satellites, Uranus has 27 satellites, and Neptune has 14 satellites\*. They revolve round the planets due to the influence of the force of gravity of their respective planets.

#### **Lesson 4 : Artificial Satellites and history of their development**

A smaller body orbiting a larger one, usually a planet, is called a satellite. An artificial satellite is a space vehicle designed to orbit a large body, usually the earth.

The moon is a natural satellite of our earth. An artificial satellite is much smaller than the moon and moves in a much smaller orbit. For every orbit there must be a definite outward centrifugal acceleration of the satellite to balance the inward attraction due to gravity. For this the velocity of a satellite is smaller when its distance from the earth is larger. It then takes more time to complete one revolution round the earth. We know that the earth revolves on its axis once in 24 hours. If an artificial satellite revolves round the earth in 24 hours, it will appear to be at rest with respect to the earth.

The history of artificial satellite is not very old. The first journey into the outer space was initiated by the Soviet Union on 4th October, 1957 when they sent the artificial satellite Sputnik 1. The meaning of the word Sputnik is travelling mate. In the same year they sent Sputnik 2 on 2nd December. The first American artificial satellite was Explorer- I, which was launched on 2nd February 1958. Vostok-1 was the first manned space mission by Soviet Union which carried the first person in space Yuri Gagarin on 12th April, 1961. Valentina Tereshkova of USSR is the first woman who went to space on 16th June, 1963 in Vostok-6. Intelset-1 was launched as communication satellite for commercial use. For remote sensing the satellite Candset-1 was launched in 1972. A satellite, named Apollo Souz test project, was sent first on a mission in 1975 for international communication. Over 5000 satellites have been launched to transmit telephone, radio and television signals around the world. Fewer than half are still orbiting and many have stopped working and are orbiting as space junk.



**Lesson 5 : The movement of an Artificial Satellite**

For the orbital motion of a satellite around the earth there must be a centripetal force working inwards. This force comes from the earth's gravitational attraction. The calculation shows that to launch a satellite into an orbit round the earth a speed of about 8 kilometer per second is needed when the satellite is lifted above 250 kilometers parallel to the earth. But it is not an easy matter to apply so much velocity to an object at this height. Because the intense friction with the atmosphere will create as much temperature that the object will be burnt and turned into ashes. This speed is achieved by using a multi-stage launching system. As the first stage motor uses up its fuel, it drops off. So the second stage rocket does not carry its weights. The speed is increased stage by stage because at lower atmosphere the air friction is larger for the higher density of air. This can create enormous heat and burn the rocket. Then the satellite begins to revolve round the earth. To understand how an artificial satellite orbits the earth you can do the following experiment.

**Activity:** To understand the revolving motion of artificial satellites round the earth.

**Methodology:** Fix a tennis ball at the end of a thread of length one meter or so. Now holding the other end of the thread, throw the tennis ball in a plane parallel to the earth's space. You will notice that after passing a little distance it shows a tendency of circular movement. If you want to revolve the ball holding the end of the thread, the ball will revolve in circle due to tension of the

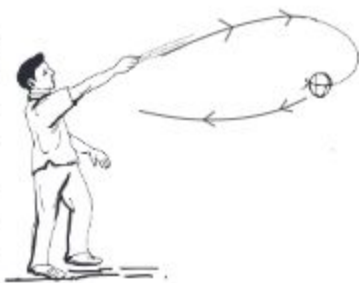

thread. Here the inward pull on the thread is analogous to the gravitational force and the outward tension on the thread is centrifugal force due to the rotational motion of the ball. The circular path of the ball is analogous to the orbit of the satellite and the ball here is representing the satellite.

You can now see why the satellite revolves in definite orbits round the earth after launching.

**Lesson 6-7 : The importance and uses of Artificial Satellites**

Artificial satellites are used for different purposes. They are named according to their uses. For example—Communication Satellite, Weather Satellite, Earth Observation Satellite, Military Satellite, Navigation Satellite and Astronomical Satellite.



**Communication Satellite**

We often communicate with the outside world over telephone. When we use the telephone a radio wave is sent through a dish antenna from our country to an artificial satellite. The satellite transmits the radio signal to the antenna of the receiving country. From there it reaches the telephone of the person with whom we are talking.

We also watch different cultural functions and games like World Cup or Olympic Games held in various countries through artificial satellites. It works in the same way where the signal is first sent to a satellite from a dish antenna which in its turn send it to our dish antenna. Finally the information is shown in our television. Here the satellite works as a relay station. This satellite carries television program and telephone news from one end of the earth to other end. For this reason the name of it is communication satellite.

**Weather Satellites**

These satellites transmit images of the weather and earth's environment. They helped to show that the ozone layer was being depleted. The news that we get through radio, television and newspaper are obtained by the use of weather satellites. It is due to weather satellites the weather forecast is possible about rainfall, wind and cyclone is possible quite in advance. This satellite can help by informing whether a forest is on fire or there lies an iceberg in the course of a ship. Besides, this satellite is used to identify the pollution of soil, water and air.

**Earth Observation Satellite**

These satellites can give us clean pictures of earth's surface. Because it can take photographs from high altitude and can observe the position of the ships in the sea and possible leakage of oil from ships causing pollution. They can observe the fields of crops over vast areas and find out where crops are growing well and where there is invasion of insects. Earth observation satellites are also used for discovering minerals and locate mountains and forests with great accuracy.

**Military Satellite**

These satellites are used by governments for military purposes. These act as spies in the sky and used to locate enemy positions and to find out whether there is any preparation for invasion by the enemy.

**Navigation Satellite**

We travel by cars, trains, ships and planes. Navigation satellites are used to locate the exact positions of vehicles, Marine vessel and aeroplane, especially when they are lost or accidents happen.

**Astronomical Satellite**

Astronomical satellites are used to observe the planets, stars, galaxies and all objects in the sky by carrying telescopes much above the atmosphere. This gives better visibility because light rays are not scattered by the air molecules of the atmosphere.

**New words :** Planets, Outer Space, Milky Way, Solar System, Satellite, Universe

**What we have learned at the end of this Chapter-**

- Planets, Stars, Milky Way exist in the space is called the outer space.
- The planets, Stars and everything from which information can reach us in one way or another constitute our universe.
- Many billions of stars that are bound together by their mutual gravitational force and move together in space as a bound system is called a galaxy. There are a vast number of stars in a galaxy and there are a vast number of galaxies in our universe.
- The galaxy to which our solar system belongs is called the Milky Way.
- The sun is a star which radiates its own heat and light and has eight planets and other objects bound to each by gravitation. The planets are Mercury, Venus, Earth, Mars, Jupiter, Saturn, Uranus and Neptune.
- The astronomical objects that revolve around the stars are called planets. The objects that revolve around the planets are called satellites.
- The objects that are sent by men to the outer space to revolve round the earth is called artificial satellite.
- According to the tasks carried out by the artificial satellites they are named as commercial satellites, Communication Satellite, Weather Satellite, Earth Observation Satellite, Military Satellite, Navigation Satellite, Astronomical Satellite etc.

## Exercise

### Fill in the blanks

1. \_\_\_\_\_ galaxies are wandering .
2. The objects revolving around the planets are called \_\_\_\_\_.
3. The galaxy to which our solar system belongs is called \_\_\_\_\_.
4. The human designed \_\_\_\_\_ are called artificial satellite.
5. The first woman to go to \_\_\_\_\_ is Valentina Tereshkova.

### Short Answer Questions

1. What is the distinction between outer space and free space?
2. Explain the vastness of the Universe.
3. What is meant by galaxy? To which galaxy do we belong?
4. What is Solar System? What objects are there?
5. Why does the artificial satellites revolve around earth?
6. Satellites serve many useful purposes - explain.

### Multiple Choice Questions

1. How many satellites are there in Jupiter?
  - a. 14
  - b. 27
  - c. 62
  - d. 67
2. galaxy is –
  - i. a vast number of stars in the universe which are bound by the gravitational force.
  - ii. the empty space between the planets and the stars.
  - iii. the heavenly objects that revolve around a star.

### Which of the following is correct?

- a. i
- b. ii
- c. i & iii
- d. ii & iii



Answer the questions no. 3 and 4 according to the table given below

Artificial Satellite	Function
M	Determining the presence of ice-berg along the path of the ship.
N	Determining the position of a plane in the sky.
O	Exploring unknown information about the Universe.
P	Gathering information about the insects attacking crops by photography.

3. Which is the satellite N?
- Communication Satellite
  - Navigation Satellite
  - Astronomical Satellite
  - Earth Observation Satellite
4. Based on the uses given in the table which two satellites are of the same type?
- M & N
  - N & O
  - O & P
  - M & P

### Creative Questions

1. The merchant Baker heard through radio from a fishing boat that cyclone is likely to come in the south of the Bay of Bengal. It can hit the shore at any moment. At the Cox's bazaar coast danger signal 3 is announced and fishing boats are asked to stay at the shore.
- What is artificial satellite?
  - What do you understand by the term Universe?
  - Where from the radio office got the information about the cyclone? How the merchant is benefited?
  - How can the news warn the merchant Backer and the coastal people? Give explanation.

2.

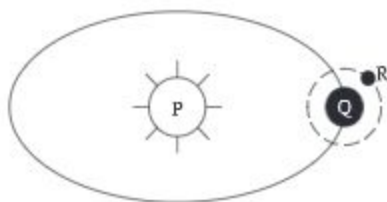

- What is outer space?
- What is the difference between the moon and an artificial satellite?
- What type of satellite is P?
- Give a comparative discussion on P, Q and R satellites.

**Project:** Design a model of solar system with the help of a teacher.

## Chapter Thirteen

# Food and Nutrition

At present there are thousands of species of animals living in this world. They show variation in their shape-size and characteristics as well as in life style, nature, food and feeding habit. Therefore, food is very essential for growth, energy and livelihood of every animal. Food is also essential for sound and healthy human body. Adequate knowledge about food and nutrition is the pre-condition of sound and healthy body. We eat organic compounds like proteins, carbohydrates, fats and oils etc. as food. We get nutrition from these food. Organic compounds which are used by organism for their growth, repair and production of energy are called food. And from these foods living beings get nutrition.



**At the end of this chapter we will be able to -**

- explain the nutrition value of different food;
- describe different means of prevention of malnutrition related diseases;
- select food-stuffs as per the requirement.

**Lesson 1: Nutrition, nutrition value and food elements**

To run an engine coal, diesel, petrol, natural gas etc. are used. Can you say what these fuel are used for? These fuel are burnt to produce energy. This energy provides speed to the vehicles. The vehicles are kept running by this energy. The human body is compared with an engine. Like other engines, energy is needed to run our body. From where we get these energy? Food fulfils the need of nutrition in our body and supplies energy.

The living organism is the main source of food. Food is mainly composed of different compounds. We get food mainly from plants and animals. By food we mean the organic elements used for the growth of body and production of energy for living beings. The ingredients of food or nutritive substances present in food perform mainly three functions of our body. For example

- Growth, repair and maintenance of the body.
- Provide heat and calorie.
- Prevent disease, ensure sound health and control metabolic activities (such as digestion, respiration, excretion etc).

**Nutrition and nutrition value**

Nutrition is a process. In this process, food is digested after eating and complex food ingredients are broken down into simple ingredients suitable to absorption. The body absorbs these simple ingredients. After absorption, the nutrients reach all the cells of the body. As a result, every part of the body regenerates the damaged cells and forms new cells for the growth of the body. Besides, food also produces heat, provides nutrition to prevent diseases and maintenance of our body. All these activities of the body are included in the nutrition process. Therefore, the nutrition elements mean the valuable elements of dietary foods which ensure energy and appropriate growth of the body, enhance merit and intelligence, prevent diseases, help for quick recovery from illness and make human beings active.

The food value of any food depends on the amount and type of elements present in food. For example, boiled rice contains 79% carbohydrates and 6% fatty substance. Besides, it contains a minute amount of proteins, vitamins and mineral salts. 345-349 kilocalorie energy is obtained from 100 gm of rice. The boiled rice contains carbohydrates, proteins and vitamins. But the amount of carbohydrates is found more in it. So, rice falls in the group of carbohydrates. In order to know the nutrition value of any food we need to know the nature of the food. The nature of food means whether it is a mixed food or pure one. In a mixed food more than one nutrition elements are present. For example, egg, milk, hotchpotch, guava, etc. On the other hand, in a pure food only one element is found. For example sugar, glucose. There is no other elements except carbohydrate in it.



## Food elements

Food is composed of a number of chemical elements. These chemical elements are called food nutrients. There is hardly any food which is made up of only one element. Based on its nutrients food is classified into three groups. For example-

1. Proteins – repair, growth and developments of the body.
2. Carbohydrates – produce energy.
3. Lipids or fats – generates heat and energy.

Beside these, other three nutrients of food are also essential. For example-

1. Vitamins – helps in prevention of disease, increases energy and stimulates different physio-chemical reactions.
2. Mineral salts – they take part in different physiological activities.
3. Water – maintains water balance of the body controls the qualities of the cells and helps in thermoregulation.

## Lesson 2-3 : Carbohydrate and protein

### Carbohydrate

We usually eat ruti, puffed rice (muri), chira, bread at our breakfast. These are carbohydrates. Carbohydrates are energy producing food. Among different elements of our daily food carbohydrate dominates. The carbohydrates are easily digested. All carbohydrates are composed of three fundamental elements, namely- carbon, hydrogen and oxygen. In our body carbohydrate provides energy for work. Glucose is a kind of simple carbohydrate.

On the basis of chemical composition carbohydrate is divided into three groups. Only one carbohydrate molecule makes monosaccharide. This is also called simple carbohydrate. Through digestion disaccharide and polysaccharide turn into simple carbohydrate (monosaccharide) and get absorbed into the body. For the balanced nutrition of the body simple carbohydrate is very important because human body can only



Fig. 13.1: Carbohydrate foods

absorb it. Of the three carbohydrates – glucose, fructose and galactose, glucose gets into the whole body through blood stream.

Among carbohydrates, lipids and proteins, carbohydrate is easily digested. Once absorbed in the body, it generates heat very quickly and supply energy to the body. One gram of carbohydrate can produce 4 kilocalorie of heat. In a human body 300-400 gm of carbohydrates can be stored. This quantity of carbohydrate is able to produce 1200-1600 kilocalorie heat and supply energy to our body.

The demand of carbohydrate depends on age, weight of the body, height and the amount of hard work. An adult male person needs 4.6 gm of carbohydrate per kilogram of his body weight. An adult person of 60 kg needs (60 x 4.6) gm or 276 gm of carbohydrate a day on an average. Out of the total requirement we should intake 60-70 percent of calorie from carbohydrate.

**Activity :** Identification of carbohydrate.

**Necessary components :** Arrowroot, rice paste, test tube, iodine, water, dropper etc

**Methodology:** Take a small amount of arrowroot or rice paste into a test tube and mix little water in it. Now pour two to three drops of iodine solution into it. Observe what happens. The solution turns blue. From this experiment, the presence of carbohydrates or starches can be determined.

### Deficiency related diseases

The intake of carbohydrate, be it more or less, both have negative impact on our body. Due to deficiency of carbohydrate malnutrition occurs. Fall of carbohydrate in blood creates metabolic disorder in the body. If there is a fall of carbohydrate in blood, symptom of hypoglycemia appears. For example—Feeling of appetite, Nausea, Excessive sweating, Irregular heart beat.

### Proteins

Protein is the composite element of our body. It is composed of carbon, hydrogen, oxygen and nitrogen. Proteins contain 16% of nitrogen. Therefore, in nutrition science protein is considered as a very important food nutrient. Protein is a complex compound of amino acids. By the process of digestion it turned into amino acids, suitable for the body to absorb. As of now a total of 22 types of amino acids have been found in the nature. The way we arrange Bangla or English alphabets to get numerous words, the proteins are produced in the same way after arranging 22 amino acids in different ways, number and types. For this reason

Some amino acids are very important for the growth, repair and balance of nitrogen of the body. These are called essential amino acids. These amino acids cannot be produced in the body. These are to be collected from food.

In food if there is deficiency of animal proteins i.e. essential amino acids, symptoms of various diseases arises. For example—nausea, increase of organic acid in urine, imbalance of nitrogen, etc.



Pulses



Milk



Fish



Meat

Fig. 13.2: Protein foods



All proteins are not equally absorbed in the body. The nutrition value of proteins depends on its digestibility. After having an intake of proteins the proportionate percentage of protein which is absorbed from the intestine is called the easily digestible quotient of the proteins. The proteins which are cent percent absorbed in the body and enhances the growth and repair has the easily digestible quotient of 1. In this case the intake of proteins and its absorption is equal. Simply it can be said that the amount of proteins taken by the organism is fully used by body for its growth and repair. If this is not done the easily digestible quotient has to be less than 1. The easily digestible quotient of breast milk and eggs is 1. The easily digestible quotient of other proteins is less than 1.

**Activity :** Identification of protein.

**Necessary components :** Egg albumin, mortar, test tube, sodium chloride, copper sulphate etc

**Methodology :** A little amount of protein (egg albumin) has to be grind with the help of a mortar. For smooth grinding a little amount of water may be added to it. Now take a small amount of protein solution in the test tube. In this solution add few drops of sodium hydroxide and copper sulphate solution. Can you see any changes in the solution?

The solution has taken violet colour following the mixing of the chemical elements with protein solution. This way the presence of protein can be determined.

### **Diseases related to the deficiency of proteins**

The body of children suffers from different protein deficiency related complications if food lacks sufficient proteins. The growth and developments of the body is also hampered. When children suffers from malnutrition, the growth of the body is stopped or delayed. The children suffer from kwashiorkor or merasmus disease due to protein deficiency.

#### **Symptoms of kwashiorkor disease**

- Children lose appetite.
- The muscle becomes scaly and weak, the skin and hair lose their smoothness and colour.
- Children suffer from diarrhoea, oedema.
- Stomach swells up.

Through proper treatment this disease can be cured, yet a kind of mental depression persists. If kwashiorkor turned acute, it may cause death of the child.



### Symptoms of marasmus disease

- The growth of the body retarded due to deficiency of both proteins and calories.
- The body gets lean and thin and reduced to a skeleton.
- The skin becomes rough and keeps falling.
- Body loses the weight.

This state is dangerous for the children. Due to protein deficiency the elderly people lose their body's resistance and causes anemia.

### Lesson 4-5 : Lipids

This is called energy producing ingredients. In lipids carbon, hydrogen and oxygen are found more in quantity. Since carbon has more combustion quality the molecules of lipid substance release more heat energy. Lipid is a compound made up of fatty acid and glycerol. The fatty substance having digested turn into fatty acid and glycerol.

The fatty acids and glycerol get absorbed in the body through lymph gland situated in villi of intestine. In lipids 20 types of fatty acids are found. Fatty acids are of two types. For example: 1. Unsaturated fatty acids and 2. Saturated fatty acids.

Fatty acid is formed in liver. But the capacity of liver to produce fatty acid is very limited. On the other hand there are some fatty acids essential for the body. These are mainly of plant origin. The usefulness of it cannot be measured by the quantity of fats present in food. The food that contains more unsaturated fatty acids is more useful. For example: Soyabean oil, sunflower oil, corn oil, sesame oil etc. The food made with these oils fall under the group of best fatty food. For example: mayonnaise, salad dressing, kasundi, oil pickles are included in the group of fatty food. The foods that contain more saturated fatty acids are called fat enriched food. For example- meat, cheese, butter, dalda, chocolate, nuts, etc. According to nutrition science out of the daily required energy for the body, 20% - 30% energy is obtained from fats. We should include those fatty food in our daily food menu which can supply essential fatty acids and can dissolve vitamins in solution.

If food lacks in fatty substance deficiency of fat soluble vitamin occurs in the body. This will result in diseases due to the deficiency of vitamin. For example: skin will get dry and rough that will ruin the beauty of the body, the children will suffer from eczema caused due to the deficiency of essential fatty acid. And elderly person lose resistance against skin disease.



Fig. 13.3: Fatty foods

**Activity :** Identification of lipids.

**Necessary components :** Soyabean oil, ethanol and water

**Methodology :** Pour few drops of soybean oil into a test tube. Now mix it with a little ethanol. Now shake the test tube very well. Now pour a little water further into the test tube and shake it again. Observe what happens. The oil solution will be of somewhat muddy colour.

Do the same experiment with the help of mustard, coconut and sesame oil and describe what happens.

### Calorie and work energy of food

The three nutrients of food-carbohydrates, proteins and fats -produce heat for the body. This heat provides energy in our body. To know about the nutritive substance and their amount, the calorie of carbohydrates, proteins and fats has to be determined. In this regard,

#### In our body

1 gram of carbohydrate can yield 4 kilocalorie of energy

1 gram of protein can yield 4 kilocalorie of energy

1 gram of fat can yield 9 kilocalorie of energy

the calorie value of vitamins, mineral salts and water has to be considered zero. In our body digestion of food, respiration, blood circulation etc. are included among metabolic activities.

The energy needed to run the metabolic activities is called basal metabolism. Furthermore, energy is also spent when we do physical labour. We gain energy from food. The heat produced from food in the body is expressed in calorie. 1000 calorie makes 1 kilocalorie. Kilocalorie is the measuring unit of heat obtained from food. The requirement of energy for the body is also determined in kilocalorie.

The need of calorie for the body of mine, yours, your younger brother and your father is not the same. In our body energy is spent in two ways. For example-1. Inside the body e.g basal metabolism and 2. Physical work. The demand of calorie or heat energy for a person depends mainly on age, height and weight of the body. Besides, the amount of energy a person uses each day varies according to sex, body-size, occupation and special conditions such as pregnancy.

In the following chart the intake of calorie and food demand is shown.

**The amount of energy used each day by children, women and men of different age group**



Age (year)	Average weight (kilogram)	Average energy (kilocalorie)	Age (year)	Average weight (kilogram)	Average energy (kilocalorie)
infants			females		
0.0- 5 Month	6	115	10-12	30	1900
6 Month - 1.0 year	9	100	13-15	42	2200
children			16-19	51	2100
1-3	13	1300	20-39	54	2000
4-6	20	1500	40-49	53	1900
7-10	28	1800	50-59	52	1800
males			60-69	51	1600
10-12	40	2200	70+	51	1400
13-15	44	2500	Extra		
16-19	67	3000	demand fo		
20-39	67	2700	pregnant		
40-49	70	2400	women for		
50-59	68	2300	first 3 months		+150
60-69	65	2200	2nd 3 months		+200
70+	65	1900	3rd 3 months		+300
			Additional		
			demand of		
			lactating mothers		+400

How will we know how much energy a person requires daily? It depends on three factors. 1. Metabolism 2. physical labour and 3. Influence of food.

Our daily foods should be according to our needs. While selecting foods we should keep in mind that the body can obtain necessary amount of caloric from food and it should contain vitamins, mineral salts and other necessary nutrients also.

### Lesson 6 : Vitamins

Through different investigations the scientists have proved that food contains a number of subtle nutrients other than carbohydrates, proteins, fats and mineral salts. In their absence body suffers from diseases like night blindness, beriberi, scurvy, etc. The term vitamin refers to an essential dietary factor which is required by the organism in small amounts and whose absence results in deficiency diseases. Thus, vitamin can be defined as potent organic compounds which must be available to the animals so that specific physiological processes (growth, replacing and repairing worn-out and damaged tissues or energy production) essential to life may proceed normally. The vitamins do not have active participation in body formation.

**Types of Vitamin:** Vitamins are divided into two sub-groups on the basis of their solubility properties. For example:



1. Fat soluble vitamins, e.g.-vitamin-A, vitamin-D, vitamin-E and vitamin-K.
2. Water soluble vitamins, e.g.- vitamin B-complex group and vitamin C.

**Source of vitamins:** Vitamins are found in green leaves, fresh branches, yellow and green leafy vegetables, fruits and seeds, etc.

### **Vitamin A**

It is found largely in fish liver oil and animal fats. Vegetables enriched with carotene such as lalshak, palong shak, puishak, tomatoes, carrots, beets and pumpkins, etc. Different fruits like papaya, mango, jackfruit contains vitamin-A, It is also found in small fish like mola, dhela etc.

### **Functions of vitamins**

To maintain good eyesight, to keep skin and mucus membrane sound, to protect the body from different contagious diseases, to help digest food and promote appetite, to keep blood in normal state and to help in nutrition and growth of the body.

### **Deficiency related diseases**

**1. Night blindness:** The symptoms of this disease is, one cannot see in inadequate ( dim) light specially at night. The children are the main victim of this disease. If it continues for a longer period of time, one might lose his eyesight. If attacked with this disease, green vegetables and coloured fruits should be added to the food menu of the children. Vitamin-A capsule can prevent this disease. In our country vitamin-A capsule has given to the children on vaccination day at different vaccination centre.

**2. Xerophthalmia:** If there is any deficiency of vitamin 'A', the cornea of one's eye may be affected. A dry layer appears on cornea. The eyes get dry and rolling of water from eyes also gets stopped. The eyes cannot tolerate light, pus gets into the eyes and the eye-lids gets swelled. If proper treatment is done, the disease may be cured. But if the treatment is not done in time the children may turn blind. Besides, if there is deficiency of Vitamin 'A', the normal growth of the body is affected. Diseases like flue, cough, influenza may cause due to this.

**Vitamin B-Complex** The function of vitamin B-complex group is to break down proteins, carbohydrates and fats as part of special enzymes and helps to release the energy from inside.

**Vitamin B1 (Thiamin):** The main function of vitamin B1 is to participate in carbohydrate metabolism and release energy. Besides, it helps to maintain normal appetite and to keep nervous system active.

**Vitamin B2 (Riboflavin):** It takes part in the metabolism of amino acid, fatty acid and carbohydrates and helps to produce energy.

**Vitamin B6 (Pyridoxine):** It helps in energy production.

### **Lesson 7 : Vitamin 'C'**

Vitamin-C is very essential nutrient for our body. This vitamin is water soluble and gets wasted in a little stroke of heat. Since it is not stored in the body, we should eat it everyday. It is found extensively in all citrus fruits like lemon, orange, shaddock, pine apple, guava, amlaki, green vegetables like cabbage, cauliflower, tomato, lettuce. Fresh vegetables and fruits contain more vitamin 'C' than the ripe ones.

Vitamin 'C' strengthens muscle and teeth, heals wounds and resist skin diseases, prevents infection in throat and nose.

#### **Deficiency related diseases**

In adults, acute shortage of vitamin C shows the following symptoms.

- Structure of bones cannot be strong.
- Bones become weak and fragile.
- Skin becomes dry, itches and the healing of wound is delayed.

#### **Scurvy**

- The gums swells up and becomes soft.
- The root of the teeth become loose and finally bleeds.
- The enamel weakens and as a result teeth fall. Children and elderly person suffer most from this disease.
- The glands swells up and mouthache is felt.
- Bleeding does not stop easily, healing of wounds delayed.
- Other diseases like flue, cough easily attack the body.

#### **Remedy**

At this stage the advice of a doctor is very essential.

#### **Prevention**

A baby should be given, along with breast milk, other supplementary foods like fruit juice, vegetable soup etc.

**Vitamin 'D'**

Vitamin 'D' is found abundant in edible oil, milk and milk products, different fish liver oil, egg yolk, butter, ghee, fats and hilsha fish.

**Functions**

- Forms structure of bones and teeth.
- Increases absorption of calcium in intestine.
- Controls the extent of calcium and phosphorous during blood circulation.

**Deficiency related diseases**

The deficiency of vitamin 'D' obstructed the absorption and accumulation of iron, and hamper hemoglobin formation.

**Rickets****Symptoms of rickets**

Due to the absence of vitamin 'D' and calcium the bones of the children becomes soft and their growth gets hampered.

- The leg bones become curved like a bow and the other bones also get curved due to the pressure of the body.
- The bone joint of hands and legs swell up.
- The ribs also turn bent.

**Remedy**

At this stage a doctor should be consulted immediately.

**Prevention**

The children should be given vitamin 'D' enriched food. Vitamin D is obtained from the cholesterol of our skin under the influence of sunlight. Therefore the children should be allowed to play in the sun for a while.

**Osteomalacia**

The rickets in elderly person is known as osteomalacia. The symptoms of this disease are as follows:

- Due to the deficiency of vitamin 'D' the absorption of calcium is hampered.
- The reserve of calcium and phosphorus reduces.
- There is a change in the function of thyroid gland.
- Since the bones weaken, their hardness also lessens and as a result there is a possibility of the bones being broken at a light stroke.

**Remedy**

If the above symptoms are visible, the advice of a doctor should be sought. Food containing appropriate amount of calcium and vitamin- D should be consumed. If needed, medicine should be taken for these food nutrients.



**Prevention**

- Ensure the consumption of vitamin -D and calcium enriched food for children.
- Children should be allowed to play in the sun for a while.

**Vitamin 'E'**

Edible oil is the best source of vitamin 'E'. Food grains, liver, fats of fish and meat contain Vitamin 'E'.

**Functions**

- Vitamin 'E' helps in cell formation.
- It takes part in some metabolic activities of the body.
- In very few cases the deficiency of Vitamin 'E' occurs and its deficiency symptoms are also negligible.

**Vitamin 'K'**

It is found in green vegetables, tomato, peas, rose hips, spinach, lettuce, cabbage, cauliflower, egg yolk, soyabean oil and liver.

**Functions**

- It produces the protein element prothrombin in the body.
- Prothrombin helps in blood coagulation.

**Deficiency related diseases**

The liver secretes bile and if there is difficulty in the secretion of bile, the absorption capacity of vitamin 'k' is reduced. The bleeding under skin and inside the body due to the deficiency of vitamin 'k' if not stopped, it may result in the death of the patient.

Due to vitamin- K deficiency bleeding of a patient, under operation is not stopped easily. Sometimes it might be fatal.

Fill in the following chequer board

Vitamin	Source	Function	Deficiency related diseases
'A'			
'B'			
'C'			
'D'			

### **Lesson 8 : Mineral salt**

Apart from the salt that we eat with rice and vegetables everyday, there are other types of salts badly needed for the body. Like proteins, carbohydrates, and fats mineral salts do not produce energy in the body. But salt is an essential elements for the body cells and body fluids. Food containing calcium, sodium, magnesium, phosphorus, chlorine, iodine, iron, sulphur etc. all get into the body and help in body formation. These elements are not found as basic elements in the body, they exist with other substances as organic and non-organic compounds. Mineral basically functions in two ways in our body. For example - it acts as an body forming element and to control the internal activities of the body. Meat, egg, milk, green vegetables and fruits are the main source of mineral salt.

Mineral salt forms the body and controls the internal functions of the body. For, the formation of bones, teeth, enzyme and hormone, stimulation of nerves, contraction of muscle, keeping the osmotic balance of the body and activating different enzymes, mineral salt is an essential element.

### **Necessity of mineral salts in human body**

Calcium forms teeth and bones, coagulates blood and performs the smooth functioning of the nervous systems. Phosphorus also forms teeth and bones and makes phospholipids. Iron forms the red blood corpuscles, helps the enzymes in their function. Iodine helps in the function of thyroid gland and help the metabolic process to run smoothly. Sodium is essential for most of the body cells and body fluids. Potassium plays a vital role in the contraction of muscle.

### **Lesson 9 : Deficiency related diseases**

**Rickets:** Calcium is absorbed along with vitamin 'D' in the body. Its deficiency causes rickets. It has been described in the section of vitamin.

**Goiter:** It is also called ghag. The prevalence of this disease is more in the northern part of our country especially in Rangpur, Dinajpur, Jamalpur and Mymensingh district. In the absence of iodine in the body the thyroid gland becomes bigger and the throat gets inflated. The symptoms of this disease are as follows:

- Inflated thyroid gland.
- Sound produced during breathing.
- Hoarseness of voice.
- Feeling discomfort in the throat and face trouble in swallowing of food.
- Patient feels dizziness and weakness.

### **Remedy**

At the early stage of this disease, iodized salt, sea fish, fish liver oil and marine algae should be eaten. If necessary a doctor should also be consulted for proper treatment.

### **Cretinism**

Usually children are exposed to this disease due to iodine deficiency. The symptoms of this disease are as follows:

- Growth of the body becomes slow.
- Thick skin and deformed face.
- Thick lips, large tongue and risk of turning mentally retarded.

### **Remedy**

Proper and timely treatment helps to overcome the problem and to maintain the normal growth of children.

### **Prevention**

Iodized salt should be eaten regularly.

### **Anemia**

Iron is the constituent element of haemoglobin of red blood corpuscles. People with iron deficiency may experience this disease. If the children and pregnant women lack iron in their food, they suffer from anemia. Usually children attacked with round worm may experience this disease.

### **Symptoms**

- Weakness and drowsiness of head and body.
- Unusually rapid palpitation.
- Dizziness and hard breathing particularly even with light work.
- Loss of weight and appetite.



### Remedy

Vegetables enriched with iron, fruits, meat, egg yolk, liver, etc. should be eaten in ample quantity. If needed a doctor may be consulted for proper medication. If the disease turns acute, the rate of blood circulation through heart may go up and one might be at the risk of heart attack following the stoppage of heart beat.

### Water

Water is an essential nutrient for our livelihood. Our body contains 60- 70% water. In the formation of the body the role of water is very much important. The water remains inside and outside the cells of bones, flesh, skin, nails, teeth etc. Almost all food contains water. But we meet our demands by drinking water separately.

Apart from body formation, water controls all the internal activities of the body. Without water no chemical reaction can take place. Water acts as solvent in the body. Different mineral salts remain dissolved in water. The digestion of food goes on in presence of water. Again the food nutrients get absorbed in the body while they remain dissolved in water.

### Function

- Water is responsible for blood circulation and thermal regulation of the body.
- Water releases waste materials from the body. For example urine, sweats.

When cholera and diarrhoea occur, a great quantity of water is released through defecation and vomit. If cholera or diarrhoea occurs, the patient should be given oral saline or water-salt beverage (Shorbot). It is the easiest treatment for cholera or diarrhoea. Besides, International Center for Diarrhoeal Disease Research of Bangladesh (ICDDR) has produced packet oral saline for this disease. It is mixed with water and then given to the patient to drink. Recently a saline, named com saline has been invented. This saline is made up of 1 litre water, 50 gm rice powder and a pinch of salt.

**Task:** Earlier you have learnt how to make oral saline. This time you again prepare oral saline. Write down what precautions you need to undertake while preparing oral saline.

### Dryness

If there is a fall in the quantity of water in the body, the cells experience shortage of water. When the cell water is reduced one gets very thirsty, the blood pressure falls, blood circulation and digestion process are hindered. The body loses weight if there is water shortage and muscles and nerve cells become weakened. If the water level of the body goes below 20 percent, the normal body function hampered, the patient gets fainted and even may run the risk of death.

## **Roughage ( dietary fibre)**

Roughage is the part of cereal grains, fruits and vegetables which is not digested. It passes almost unchanged through the gut. It is not a nutrition element. But it is very essential to maintain a sound health. Roughage in grains is called bran. Roughage in fruit and vegetables is the cellulose walls of plant cells. We get roughage from fibre foods.

## **Food selection**

The foods which meet the demand of the calorie of the body, maintain the growth and formation of tissue cells and control the metabolic activities of the body is called balanced diet. Therefore by balanced food we mean the correct amount of food and the correct proportions of each (six) type of food that meet the demands of the body of a particular person.

The necessary nutrition elements of food remain in specific quantity in a balanced diet depending on age, sex, physical condition, work load etc. A balanced diet chart should be made following some instructions. Such as-

1. In every single meal of the day the inclusion of six food elements including protein, carbohydrates and fats should be confirmed.
2. Food from each group has to be supplied based on age, sex and occupation.
3. Out of total daily intake of calorie 60-70% from carbohydrates, 10% from proteins and 30-40% from fatty foods should be taken.

## **List of balanced diet**

Following some guidelines we can make the list of balanced diet. For example:

1. Firstly the list has to be made based on the understanding that the requirements of different food elements vary according to age, occupation, and physical status of a particular person.
2. The daily required total energy should be ensured according to the needs of one's body.
3. The food should contain correct proteins needed for body formation and the prevention of its decay.

4. Ensure the presence of appropriate vitamins, mineral salts and water in food.
5. To acquire knowledge about nutrition value and classification of food. First we have to select food from the main divisions of food. There should be variety in food selection.
6. There should be awareness about food habit while selecting food.
7. The food list has to be prepared matching with the financial ability of an individual and a family as well.
8. While preparing the list season and weather condition should be taken into consideration.

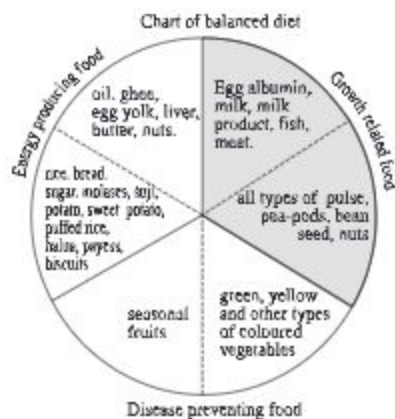

**New words :** Protein, carbohydrate, lipid, vitamin, easily digestible quotient, amino acid, kwashiorkor, marasmus, xerophthalmia, scurvy, rickets, osteomalacia, prothrombin, cretinism, anemia.

### What we have learned at the end of this chapter-

- The fundamental metabolism is the energy required to run metabolism process.
- Vitamins and mineral salts are not separate types of food. These all are obtained from other food-stuffs.
- Water is a very essential nutrient for the body. The digested foods being dissolved in water, transported to all parts of the body.

## Exercise

### Short Answer Questions

1. What is kilocalorie?
2. What are the symptoms of rickets?
3. What are the diseases caused due to the deficiency of vitamin 'A'?
4. What is the necessity of hemoglobin in blood ?



**Multiple Choice Questions**

1. Which one produces heat and energy of the body?
  - a. Water
  - b. Vitamin
  - c. Fats
  - d. Mineral salts
2. The deficiency of which vitamin causes rickets in children?
  - a. Vitamin 'A'
  - b. Vitamin 'C'
  - c. Vitamin 'D'
  - d. Vitamin 'E'

**Read the following paragraph and answer questions no. 3 & 4**

Sumi does not like sour. Even she does not like green vegetables and tomatoes. Recently she has been experiencing bleeding from her gums.

3. What disease has attacked sumi?
  - a. Scurvy
  - b. Rickets
  - c. Merasmus
  - d. Kwashiorkor?
4. What happens to the elderly person due to the deficiency of foods mentioned in the paragraph?
  - i. the bones becomes soft
  - ii. the skin itches and wounds
  - iii. pain in thoracic cage and ribs appears

**Which one is correct?**

- a. i & ii
- b. i & iii
- c. ii & iii
- d. i, ii & iii

**Creative Questions**

1. Nowadays Talha doesn't want to eat anything. He has developed somewhat apathy towards food and nausea. His skin is getting rough. The doctor, when contacted, advised him to eat more eggs and drink milk in more quantity.
  - a. What is food?
  - b. What do we understand by nutrition?
  - c. Why did the doctor advised Talha to eat the above mentioned food?
  - d. What may happen to Talha afterwards if Talha does not eat the food prescribed by the doctor?
  
2. Noorjahan Begum is too much concerned about the physical growth of her eight year old son Bakul. To ensure Bakul's physical growth and sound health, she started feeding her son with some especial types of food. But she put different types of food in the food menu of herself, her husband, Bakul's grand father and grandmother.
  - a. What is protein?
  - b. What do we understand by roughage?
  - c. How does Noorjahan Begum prepare the food chart for Bakul? Describe.
  - d. Justify the rationale behind the selection of different foods for the members of Noorjahan Begum's family?

## Chapter Fourteen

# Environment and Ecosystem

You know, our environment comprises of everything that we have around us. It is also known to you that, the living organisms and non-living matters of an area constitute the environment of that particular area. You must have observed that, there are different types of environment on earth. We may categorise them into three main heads, namely, fresh water, marine water and land. Each of these three environment also have special types of biotic and abiotic factors.

These living and non-living components are interrelated with each other. You know, among living components of the environment, there are plants and animals of different types. For survival, these plants and animals are interdependent and interrelated with each other.



**At the end of this chapter, we will be able to–**

- explain different environmental components and environmental types;
- explain food chain and food web;
- explain the flow of energy in the ecosystem;
- analyze the role of ecosystem in maintaining environmental ( ecological) balance;
- realize the impact of ecosystem on living beings and make aware of the protection of ecosystem.



## Lesson 1 : Ecosystem

There are different types of living organisms in different environment of the world. In different regions of each habitat, there exists a vast dissimilarity in their climatic condition, weather and other abiotic and biotic factors. For these dissimilarity, the earth is inhabited by various different types of organisms. The organisms you see in the forest are different from those inhabited in the pond. There is a close relationship between biotic and abiotic components of these environment. Further, the animals, plants of an environment are dependent on one another for their survival. In this way, the living component of a particular environment is functioning and interacting with the abiotic components to form a relatively stable system, called ecosystem.

If you observe environment, you will see there is a continuous action-reaction among different components of the ecosystem. The garden near your house or school is the example of a small ecosystem.

## Lesson 2 : Components of ecosystem

As you know, ecosystem consists of abiotic (non-living) and biotic (living) components.

**Abiotic components:** All non-living components of an ecosystem is abiotic components. These are classified into two categories: (a) Inorganic or physical components and (b) Organic substances. Inorganic component consists of minerals, soil, light, water, air, temperature, humidity, etc. Dead and decomposed organic materials of living organisms are known as organic substances. These inorganic and organic components are very essential for the survival of the living organism.

**Biotic components:** Biotic components include plants, animals and micro-organisms. As you have learnt in lesson one, there is an interrelationship between biotic and abiotic components. To keep ecosystem functional, these living organisms play certain role and on the basis of their contribution biotic components are of three types, for example - (a) Producer (b) Consumer and (c) Decomposer.

**(a) Producers:** The green plants can produce food hence called producers of the ecosystem. They manufacture carbohydrate food in presence of sunlight by the process of photosynthesis. All the animals of an ecosystem are directly or indirectly dependent on this food.

**(b) Consumers:** The animals which live on eating organic matters obtained from plants or on other animals are known as consumers. These consumers are again divided into three groups-

**Primary consumers:** All animals which consume plants or plant parts are known as primary consumers. They are also called herbivores. From minute insect to many large animals are included in the group of herbivores. For example- cow, goats etc.

**Secondary consumers:** Those which live on eating primary consumers. For example frog, bird, man etc. They are also called carnivores.

**Tertiary consumers:** Animals which feed on secondary consumers are called tertiary consumers. For example- frog, tortoise, stork, man etc. Some of these animals take food from more than one food level (trophic level). They are called omnivores. When we take pulse, rice, potato etc. we are primary consumers or herbivore. But when we eat fish and meat , we are secondary or tertiary consumers.

**(c) Decomposers:** These are wide range of microorganisms including bacteria and fungi. After the death of plants and animals these micro-organisms act on their bodies and decompose. Finally, the decomposed body forms different organic and inorganic components. Some of the nutrients are used by them and the rest are mixed up with the soil and air. The green plant again consumes those as a natural process. These action and reaction, between the biotic and abiotic components of the nature, has created the ecosystem as a potential self-supporting ecological unit.

### **Lesson 3-5 : Types of ecosystem**

In natural environment, there are two types of ecosystem. They are ecosystem of land and ecosystem of water. In this lesson you will learn about ecosystem of land and ecosystem of water.

**Land ecosystem:** Land ecosystem may be of different types. For example- ecosystem of forest, ecosystem of desert, etc. The forest region of Bangladesh may be mentioned as the example of forest ecosystem. The forest of Bangladesh is divided into two main regions. (a) The forest of Sylhet and Chittagong hill tracts and (b) The Sundarbans forest of coastal region of Khulna. A brief description of the ecosystem of Sundarbans are given below-

The Sundarbans is a single large forest of Bangladesh. The vegetation of Sunderbans is different from the vegetation of other forests. The Sundarbans is situated in the southern region of Khulna district skirting the coastal belt of the Bay of Bengal. In the ecosystem of the Sunderbans the soil is of high salt density. As salinity increases coastward in the tidal and sub-tidal areas, there is a transition of dense mangrove vegetation. The soil of the Sundarbans is very muddy. So, it is not suitable for air passing. So the branch roots of the plants of this region grow erect and spread along the upper layer of the soil instead of inward. Root tip of these plants bear numerous spores through which atmospheric oxygen enters into the plant body for respiration. The sundari, garan, gewa, kewra, golpata, etc. are the major plants of the forest. They are the producers of the ecosystem. Insects, birds, deer, etc. are primary consumers.



Jackals, tortoises, cranes etc. are secondary consumers. Tiger, hogs, etc. are among the tertiary consumers. Among them hogs are omnivorous. The Royal Bengal Tiger, chita, monkey, spotted deer, wild hogs, crocodiles, different types of snakes, birds and insects are the major animals of the Sundarbans.

**Aquatic ecosystem:** Aquatic ecosystem is divided into three main types—

1. Ecosystem of ponds
2. Ecosystem of rivers
3. Marine ecosystem.

An ecosystem of a pond is described here briefly for your understanding. A classic example of an aquatic ecosystem is the ecosystem of a small pond. In fact, a pond is an ecologically independent and self-regulating unit. In a pond there exist abiotic and biotic components. The abiotic components are water, dissolved oxygen, carbon dioxide and some organic matters. Organisms can use these elements directly. The elements that constitute the biotic components of a pond ecosystem are producers, primary consumers,

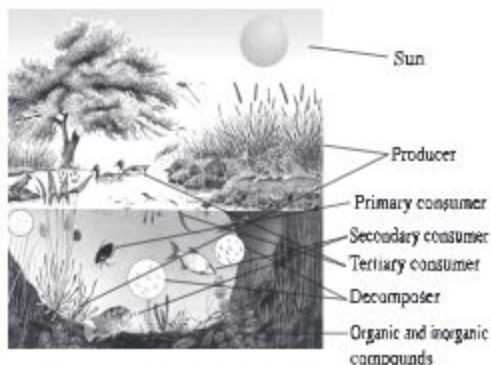

Fig. 14.1: Ecosystem of a pond

secondary consumers, tertiary consumers and decomposers of different types. In a pond ecosystem producers are minute floating or suspended small plants, known as phytoplankton. Water lily (Shapla), Eichhomia etc. are among floating macrophytes. Like minute floating plants, there are also some microscopic animals known as zooplankton. Aquatic insects, small fish, mussels, snails etc. feed on producer and is known as primary consumers. Medium sized fishes those live on eating the primary consumers, are called secondary consumers. Again, big fish, stork etc. who eat secondary consumers are tertiary consumers. Bacteria, fungi decompose dead organisms. The decomposed substances are again used by the producer of the pond ecosystem.

### Lesson 6-7: Food chain and Food web

You know that living beings of an ecosystem cannot live alone. For survival, they are interdependent in various ways. All the components surrounding the living beings, influence the survival of organisms in different ways.

**Food chain:** Sunlight is the source of all energy of the earth. Green plants are the producer of the ecosystem. You know primary consumer depends on producer for food. Again, secondary consumer depends on primary consumers. Tertiary consumers live on eating secondary consumers. In this way, all organisms (both plants and animals) of an ecosystem, are interconnected



serially. Consequently, there develops a food chain. The transfer of food energy from producers through a series of food levels i.e. herbivores (primary consumers) to carnivores, carnivores (secondary and tertiary consumers) to decomposers in the ecosystem is called food chain. Thus, the food chain is a feeding relationship in which a carnivore eats a herbivore which eats plants.

For example : Grass  $\rightarrow$  insect  $\rightarrow$  frog  $\rightarrow$  snake  $\rightarrow$  eagle.

**Food web:** You must observe there are numerous food chains in an ecosystem. Food chain does not work in isolation. Rather most food chains connect other chains. Food chains are linked together to form a food web. Naturally in any ecosystem more than one food chain remain attached to each other and this complex food chain of more than one is known as food web.

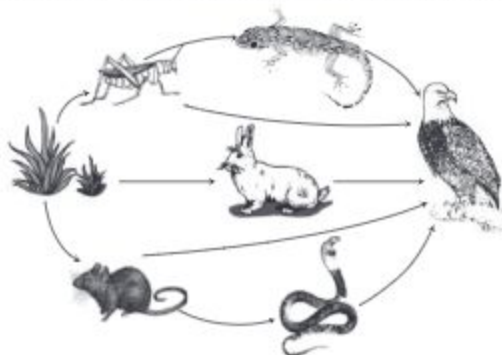

Fig. 14.2: Food web

## Lesson 8-9 : Energy flow in the ecosystem

You know all organisms living on earth are dependent on solar energy (sunlight). So, the sun is the main source of energy for the living world. Green plants trap only 2% of the total energy reached on earth and produce carbohydrate food through photosynthesis. Green plants through photosynthesis process convert solar energy to chemical energy, naturally. During this process, green plants use natural compounds like-water, nitrogen, carbon dioxide, iron, sulphur, etc. By this process, a bridge between living and non-living world is established.

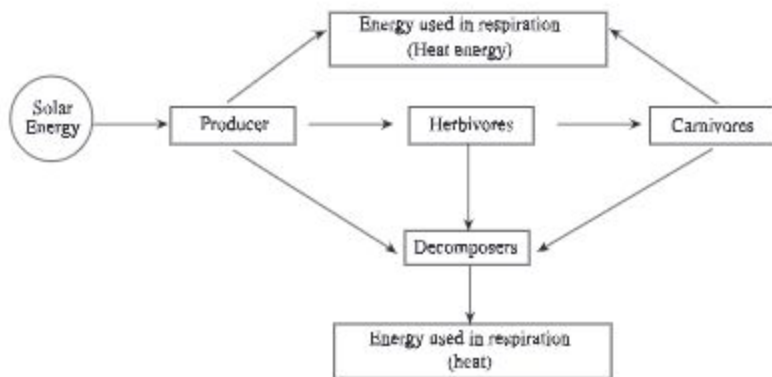

Fig. 14.3 : Linear flow of energy and cyclic movement of matters in the ecosystem.

The green plants receive the solar energy and transform it into chemical energy and initiates food chain. The flow of energy in the ecosystem takes place in this food chain. The energy content at successive trophic levels, from producers to tertiary consumers, gradually decreases. So, it is evident that energy flows from producers to herbivores; herbivores to secondary consumers and from secondary consumers to tertiary consumers. This is how the energy flows. When decomposers act on dead bodies or on garbage, different non-living nutritive substances of ecosystem are produced. The green plants again consume them. It is understood from the fact that, nutritive substances show circular movement and the flow of energy is linear.

### **Lesson 10: Role of ecosystem in maintaining balance of nature**

Ecosystem is a self-sufficient and self-regulating unit. The living organisms depend on one another. One living being binds another in the food chain. One living organism cannot get increased in number, nor can it become extinct easily. Consequently, the number of living organisms at different trophic levels remains more or less constant. Different changes may occur in nature, still the balance of nature is maintained for longtime. Let us try to understand the matter with an example. Suppose, there lives tigers, deer and hogs in a forest. Tigers eat deer and hogs as their food. If due to any reason the number of deer and hogs get increased in nature, the number of tigers will increase. The reason is, tigers get enough food. Again, if the number of tigers get increased, the number of deer and hogs will be decreased. Thus, the number of tigers will be decreased due to inadequate food supply. Further, if the number of tigers is decreased, the number of deer and hogs will be increased. From the example it is clear that the number of increased organisms (tiger) will be reduced soon and it returns to the previous condition. In this way, natural balance of an ecosystem is maintained naturally.

**Task:** To prepare a report about the role of ecosystem in maintaining natural balance group. Prepare an example in your notebook for a particular environment regarding how ecosystem maintains the balance of nature. Present it in front of your class.

**New words :** Ecosystem, food chain, food web, phytoplankton, zoo plankton.

### **What we have learned at the end of this chapter-**

- The interrelationship, action-reaction and interdependence between biotic and abiotic components of a particular environment constitute an ecosystem.
- Ecosystem consists of two main components, namely, biotic and abiotic components.
- Starting from plant source the transfer of energy by eating and being eaten up by different animals, is known as food chain.
- In nature, most food chains connect other chains. This complex food chain of more than one is known as food web.

## Exercise

### Fill in the blanks

- The animals which \_\_\_\_\_ are primary consumers.
- Non-living components of an ecosystem are known as \_\_\_\_\_ components.
- In nature, living organisms are interrelated with one another by different \_\_\_\_\_.
- Due to action-reaction between biotic and abiotic components in nature \_\_\_\_\_ remain active.

### Short Answers Questions

- Describe pond ecosystem with as a figure.
- Discuss how nature maintains environmental balance.

### Multiple Choice Questions

- Which one of the following is primary consumer?
 

a. Phytoplankton	b. Snail
c. Tiger	d. Stork
- Which one of the following food chain is correct?
 

a. Phytoplankton	→	Small fish	→	Zooplankton
b. Fruit	→	Insect	→	Bird.
c. Grass	→	Tortois	→	Small Fish
d. Khudepana	→	Fish	→	Snail.

**Based on the following chart answer questions no. 3 and 4**

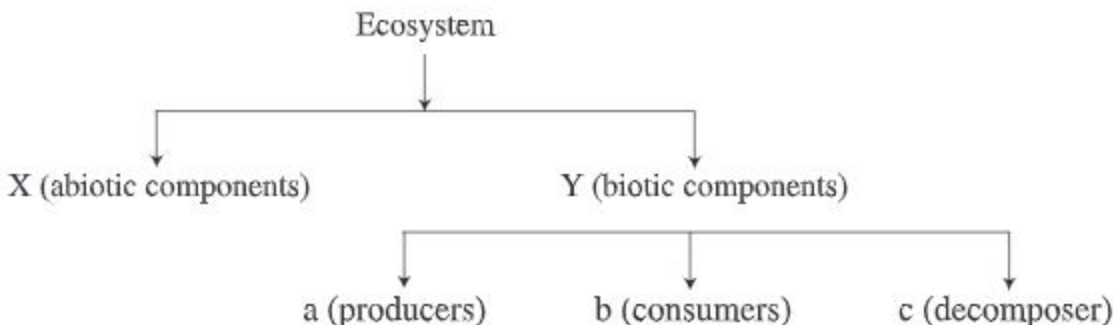



3. Which one of the following is included under c?
- a. Phytoplankton  
b. Zooplankton  
c. Bacteria  
d. Insects
4. In the above chart-
- i. Y is dependent on X  
ii. 'b' is dependent on 'a'  
iii. 'a' and 'c' are interdependent.

**Which one of the following is correct?**

- a. i & ii  
b. i & iii  
c. ii & iii  
d. i, ii & iii

### Creative Questions

1. Fahim during his visit to a forest saw different types of plants and varieties of animals. They include rabbit, deer, monkey, tiger hogs, etc. During his visit he witnessed the felling of large trees in an area and the low presence of those animals there.
- a. What is ecosystem?  
b. What do you mean by decomposer?  
c. Make a food chain with the above mentioned animals that Fahim witnessed and explain.  
d. Explain causes of decline of the number of animals in the area where felling of trees take place.
- 2.

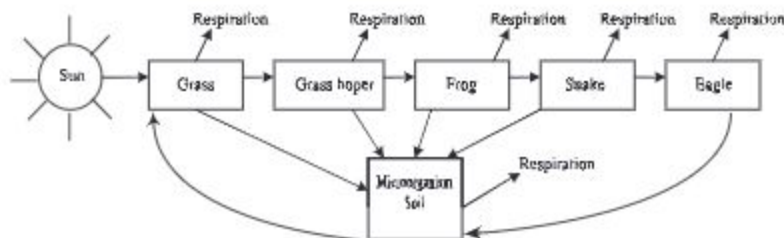

- a. What is a biotic component?  
b. What do you mean by food web?  
c. Explain the flow of energy in the above mentioned food chain?  
d. What would be the nutrient cycle of the above mentioned stem? Analyse.

**Project:** Observe a couple of food chains of the environment. After observation, make a food web in a poster paper with the help of these food chains and show it to the classroom.

\*\*\* END \*\*\*

# 2025 Academic Year

## Eight–Science

পরিশ্রম কখনও নিষ্ফল হয় না।

